

SIEMENS

Siemens BT300 HVAC Drive Installation Instructions

Copyright Notice

Notice

Document information is subject to change without notice by Siemens Industry, Inc. Companies, names, and various data used in examples are fictitious unless otherwise noted. No part of this document may be reproduced or transmitted in any form or by any means, electronic or mechanical, for any purpose, without the express written permission of Siemens Industry, Inc.

All software described in this document is furnished under a license agreement and may be used or copied only in accordance with license terms.

For further information, contact your nearest Siemens Industry representative.

Copyright 2019 Siemens Industry, Inc.

To the Reader

Your feedback is important to us. If you have comments about this manual, please submit them to: SBT_technical.editor.us.sbt@siemens.com

Other product or company names mentioned herein may be the trademarks of their respective owners.

Printed in the USA.

Table of contents

Chapter 1 - Safety	5
Dangers	6
Warnings	9
Notices.....	9
Grounding and Ground Fault Protection	10
Chapter 2 - Receipt of Delivery	12
Product Numbers	12
Unpacking and Lifting the Drive	13
Lifting Frames FS8 and FS9	13
Accessories.....	14
Size FS4	15
Size FS5	15
Size FS6	16
Size FS7	16
Size FS8	17
Size FS9	17
Chapter 3 - Mounting	18
Dimensions in Millimeters (Inches).....	18
Wall Mount	18
Flange Mount.....	26
Cooling.....	26
Chapter 4 - Power Cabling	29
UL Criteria for Cabling and Fusing	30
Cable Dimensioning.....	30
Fuse Sizing	30
Cable Installation	32
Frames FS4 to FS7	33
Frames FS8 and FS9	40
Installation in Corner-Grounded Network.....	49
Chapter 5 - Control Unit	50
Control Cable Sizing	51
Control Terminals and DIP Switches	51
Selecting Terminal Functions and Isolating Digital Inputs from Ground with DIP Switches.....	53
I/O Cabling and Fieldbus Connection	54
Prepare for Use with Ethernet	54
Ethernet Cable Data	54
Prepare for use through RS-485.....	56
RS-485 Cable Data	56

Option Board Installation	61
Battery Installation for Real Time Clock (RTC)	62
Galvanic Isolation Barriers	62
Chapter 6 - Commissioning	64
Commissioning the Drive	65
Running the Motor	66
Cable and Motor Insulation Checks	67
Installation in an IT System	67
Frames FS4 to FS6	68
Frames FS7 and FS8	71
Frame FS9	73
Maintenance	75
Chapter 7 - Technical Data	77
Drive Power Ratings	77
Definitions of Overload	77
Technical Data	78
Fieldbus Technical Data	80
Control Board Technical Specifications	81



Chapter 1 - Safety

This manual contains clearly marked Caution, Warning, and Danger notices, which are intended for your personal safety and to avoid any unintentional damage to the product or connected devices.

Please carefully read the information included in the Caution and Warning notices.

The following table lists the safety symbols used in this manual to draw attention to important information.

Table 1: Warning Symbols.

Symbol	Description
	DANGER or WARNING : Dangerous voltage is present. DANGER ou AVERTISSEMENT : Présence de tension dangereuse.
	WARNING or CAUTION AVERTISSEMENT ou ATTENTION
	NOTE REMARQUE

The following table describes the safety notices used in this manual to draw attention to important information.

Table 2: Warning Descriptions.

Warning Type	Description
DANGER	Serious injury, death, or severe equipment damage is imminent if a procedure or instruction is not followed as specified. Le non respect d'une procédure ou instruction peut provoquer instantanément des blessures graves, voir mortelles, ou endommager l'équipement
WARNING	Serious injury, death, or severe equipment damage could occur if a procedure or instruction is not followed as specified. Le non respect d'une procédure ou instruction peut provoquer des blessures graves voir mortelles ou endommager l'équipement.
CAUTION	Minor or moderate injury may occur if a procedure or instruction is not followed as specified. Le non respect d'une procédure ou instruction peut provoquer des blessures mineures ou modérés.
NOTICE	Equipment damage or unwanted operation may occur if a procedure or instruction is not followed as specified. Le non respect d'une procédure ou instruction peut endommager l'équipement ou entraîner un fonctionnement intempestif.
NOTE	Notes provide additional information or helpful hints. Les remarques fournissent des informations supplémentaires ou des conseils utiles.

Dangers

	<p>⚠ DANGER</p>
	<p>The components of the power unit of the BT300 Drive are live when the drive is connected to the primary input voltage. Coming into contact with this voltage is extremely dangerous and may cause death or severe injury.</p> <p>Les composants de l'unité d'alimentation du variateur Siemens BT300 sont sous tension lorsque le variateur est connecté à la tension principale. Tout contact avec cette tension est extrêmement dangereux et peut provoquer des blessures graves; voire mortelles</p>

	<p>⚠ DANGER</p>
	<p>The motor terminals U, V, W and the R+ and R- terminals are live when the BT300 Drive is connected to line voltage, even when the motor is not running.</p> <p>Les bornes U, V W du moteur, et les terminaux R+ et R- sont sous tension lorsque le variateur BT300 est connecté à la tensions de ligne, même si le moteur n'est pas en marche.</p>



⚠ DANGER

Always ensure absence of voltage before starting any electrical work!

After disconnecting the drive from line voltage, **wait** until the indicators on the keypad go out (if no keypad is attached see the indicators on the cover). Wait 5 more minutes before doing any work on the connections of the BT300 Drive. Do not open the cover before this time has expired. After expiration of this time, use a measuring equipment to absolutely ensure that **no voltage is present**.

Veillez vous assurer en toute circonstance que la tension d'alimentation est coupée avant tout raccordement électrique.

Après avoir débrancher le variateur de la tension de ligne, **vous devez attendre** l'extinction des voyants sur le panneau opérateur (si aucun panneau opérateur n'est raccordé, voir les voyants sur le capot). Attendez cinq minutes supplémentaires avant de commencer tout travail sur les bornes du variateur Siemens BT300. Ne pas ouvrir le capot avant la fin de cette période d'attente. À l'expiration de cette période, utilisez un instrument de mesure pour vous assurer **qu'aucune tension n'est présente**.



⚠ DANGER

The control I/O-terminals are isolated from the primary input voltage. However, the **relay outputs and other I/O-terminals may have a dangerous control voltage** present even when the BT300 Drive is disconnected from line voltage.

Les bornes d'E/S de commande sont isolés de la tension de ligne. Cependant, les **sorties relais et les autres bornes d'E/S peuvent être alimentées en tension de commande dangereuse**, même lorsque le variateur Siemens BT300 est hors tension.



⚠ DANGER

Before connecting the drive to the primary input voltage make sure that the front and cable covers of the BT300 Drive are closed.

Avant de brancher le variateur à la tension de ligne, assurez-vous que les capots avant et de câblage du variateur Siemens BT300 sont fermés.



⚠ DANGER

During a ramp stop (coast stop) (see the *Siemens BT300 Operator's Manual* (DPD01809), the motor is still generating voltage to the drive. Therefore, do not touch the components of the drive before the motor has completely stopped. Wait until the indicators on the keypad go out. (If no keypad is attached see the indicators on the cover.) Wait an additional 5 minutes before starting any work on the drive.

Durant un arrêt en rampe (un arrêt en roue libre) (voir le *Siemens BT300 Operator's Manual* (DPD01809)), le moteur continue à produire de la tension sur le variateur. Par conséquent, ne touchez en aucun cas les composants du variateur avant l'arrêt complet du moteur. Attendez l'extinction des voyants sur le panneau opérateur (si aucun panneau opérateur n'est raccordé, voir les voyants sur le capot). Attendez cinq minutes supplémentaires avant de commencer tout travail le variateur.



⚠ DANGER

Do not perform any measurements when the drive is connected to line voltage.
N'effectuer aucune mesure lorsque le variateur est raccordé à la tension de ligne.



⚠ DANGER

The **earth leakage current** of the BT300 Drive exceeds 3.5 mA AC. According to standard EN61800-5-1, a **reinforced protective ground connection** must be ensured. See the section Earth grounding and ground fault protection.





Le **courant de fuite à la terre** du variateur Siemens BT300 dépasse 3,5 mA AC. Selon la norme EN61800-5-1, un **raccordement de mise à la terre à protection renforcée** doit être mis en place. Voir la section Earth grounding and ground fault protection.

Warnings



	<p>⚠ WARNING</p>
	<p>At power-up, power brake, or fault reset, the motor will start immediately if the start signal is active unless pulse control has been selected for Start/Stop logic. Furthermore, the I/O functionalities (including start inputs) may change if parameters, applications or software are changed. Therefore, disconnect the motor if an unexpected start can cause danger.</p> <p>Lors d'un démarrage ou d'une réinitialisation, le moteur redémarrera immédiatement si le signal de démarrage est actif, à moins que la commande à impulsion n'ait été sélectionnée pour la logique Démarrage/Arrêt.</p> <p>De plus, les fonctionnalités d'E/S (y compris les entrées de démarrage) peuvent changer si les paramètres, les applications ou le logiciel changent. Déconnectez donc le moteur, si un démarrage inopiné peut poser un danger.</p>
	<p>⚠ WARNING</p>
	<p>The motor starts automatically after an automatic fault reset if the auto restart function is activated. See the <i>Siemens BT300 Operator's Manual</i> (DPD01809) for more detailed information.</p> <p>Le moteur démarre automatiquement après une réinitialisation automatique si la fonction redémarrage auto est activée. Voir le <i>Siemens BT300 Operator's Manual</i> (DPD01809) pour plus d'information.</p>
	<p>⚠ WARNING</p>
	<p>Before making measurements on the motor or the motor cable, disconnect the motor cable from the drive.</p> <p>Avant d'effectuer des mesures sur le moteur ou le câble du moteur, débrancher le câble du variateur.</p>

Notices

	<p>NOTICE</p>
	<p>The Siemens BT300 Drive is meant for fixed installations only.</p>
	<p>NOTICE</p>
	<p>If the drive is used as a part of a machine, the machine manufacturer is responsible for providing the machine with a supply disconnecting device (EN 60204-1).</p>

	NOTICE
	Only spare parts delivered by Siemens Industry, Inc. can be used.
	NOTICE
	Do not touch the components on the circuit boards. Static voltage discharge may damage the components.
	NOTICE
	Check that the EMC level of the drive corresponds to the requirements of your supply network. See the Installation in an IT System [→ 67] section.
	NOTICE
	In a domestic environment, this product may cause radio interference. In this case, additional mitigation measures may be required.
	NOTICE
	The drives are suitable for use on a circuit capable of delivering not more than 100,000 rms symmetrical amperes, 600V maximum.

Grounding and Ground Fault Protection

	⚠ WARNING
	<p>The Siemens BT300 Drive must always be grounded with a grounding conductor connected to the grounded terminal marked with .</p> <p>Le variateur Siemens BT300 doit toujours être mis à la terre avec un conducteur de protection connecté à la borne de mise à la terre marquée .</p>

The touch current of the BT300 Drive exceeds 3.5 mA AC. According to EN 61800-5-1, a fixed connection and one or more of the following conditions for the associated protective circuit must be met:

- The **protective grounding conductor** must have a cross-sectional area of at least 8 AWG (10 mm²) Cu or 6 AWG (16 mm²) Al.
- or
- An automatic disconnection of the supply in case of discontinuity of the **protective grounding conductor**. See *Chapter 4 Power Cabling*.

- or
- Provision of an additional terminal for a second **protective grounding conductor** of the same cross-sectional area as the original **protective grounding conductor**.

Table 3: Protective Grounding Conductor Cross-Section.

Cross-sectional area of phase conductors (<i>S</i>) AWG (mm ²)	Minimum cross-sectional area of the corresponding protective grounding conductor AWG (mm ²)
<i>S</i> ≤ 6 (16) 6 (16) < <i>S</i> ≤ 35 (2) 35 (2) < <i>S</i>	<i>S</i> 6 (16) <i>S</i> /2 (14)
The values in this table are only valid if the protective grounding conductor is made of the same metal as the phase conductors. If this is not the case, the cross-sectional area of the protective grounding conductor must be determined in a manner which produces a conductance equivalent to that which results from the application of this table.	

The cross-sectional area of every protective grounding conductor which does not form a part of the supply cable or cable enclosure shall, in any case, not be less than:

- 14 AWG (2.5 mm²) if mechanical protection is provided, or
- 12 AWG (4 mm²) if mechanical protection is not provided.
- For cord-connected equipment, provisions shall be made so that the protective grounding conductor in the cord shall, in the case of failure of the strain-relief mechanism, be the last conductor to be interrupted.

However, always follow the local regulations for the minimum size of the protective grounding conductor.

!	NOTICE
	Do not perform voltage withstand tests on any part of the BT300 Drive. A procedure is in place, according to which the tests must be performed. Ignoring this procedure may result in product damage.



NOTE:

Due to the high capacitive currents present in the drive, fault current protective switches may not function properly.

Chapter 2 - Receipt of Delivery

Check the accuracy of the delivery by comparing your order data to the drive information found on the package label. If the delivery does not correspond to your order, contact the supplier immediately.

Product Numbers

Siemens product numbers consist of 15 characters and one optional character for factory-installed options. Each segment of the product number uniquely corresponds to the product and options you have ordered. Following is the product number format:

	Example:	BT300	-	0	0	1	X	2	-	0	1	X
	Example:	BT300	-	0	0	1	5	4	-	1	2	D
	Model(s)											
		BT300	VFD Only									
	Separator											
	HP											
		1 ¹⁾ , 1.5 ²⁾ , 2 ²⁾ , 3, 5, 7.5, 10, 15, 20, 25, 30, 40, 50, 60, 75 ³⁾ , 100 ³⁾ , 125 ³⁾ , 150 ⁴⁾ , 200 ⁴⁾ , 250 ⁵⁾										
		X = no fraction, 5 = 1/2 hp										
	Voltage											
		2	208 Vac to 240 Vac									
		4	380 Vac to 500 Vac									
		6	525 Vac to 600 Vac									
	Separator											
	NEMA											
		00 ⁶⁾	Chassis Version (IP 00)									
		01	NEMA Type 1 (IP 21)									
		12	NEMA Type 12 (IP 54)									
	Type											
		X	Drive Only									
		D	Disconnect ⁷⁾									

BT0115R3

- ¹⁾ Available only with voltage code 2.
- ²⁾ Available only with voltage code 2 or 4.
- ³⁾ Use with voltages equal to or greater than 230 Vac.
- ⁴⁾ Available only with voltage code 4 or 6.
- ⁵⁾ Available only with voltage code 4.
- ⁶⁾ Available only with 50 hp and above @ 208 Vac or 100 hp and above @ 480 Vac (FS8 and FS9).
- ⁷⁾ Available only with NEMA Type 12 with 30 hp and below @ 240 Vac or 60 hp and below @ 480 Vac or 50 hp and below @ 600 Vac.

Example Product Numbers:

BT300-001X2-01X

BT300, 1 hp, 208 to 240 Vac, NEMA Type 1, Drive Only

BT300-00154-12D

BT300, 1.5 hp, 380 to 500 Vac, NEMA Type 12, Drive with disconnect

Unpacking and Lifting the Drive

The weights of the drives vary greatly according to the size. You may need to use special lifting equipment to remove the drive from its package. Note the weights of each individual frame size in the table below.

Table 4: Frame Weights.

Frame	Weight in kgs (lbs)
FS4	6.0 (13.2)
FS5	10.0 (22)
FS6	20.0 (44.1)
FS7	37.5 (82.7)
FS8	66.0 (145.5)
FS9	108.0 (238.1)

If you require special lifting equipment, see the figure in the *Lifting frames FS8 and FS9* section for lifting instructions.

Lifting Frames FS8 and FS9



NOTES:

1. First detach the drive from the pallet it has been bolted to.
 2. Place the lifting hooks symmetrically in at least two holes. The lifting device must be able to carry weight of the drive.
 3. The maximum allowed lifting angle is 45 degrees.
-

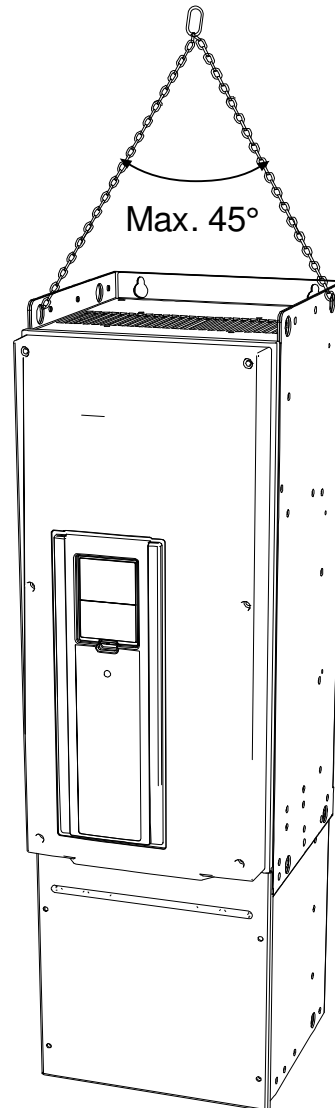

9012.emf

Figure 1: Lifting Bigger Frames.

Siemens BT300 HVAC Drives have undergone scrupulous tests and quality checks at the factory before they are delivered to the customer. However, before and after unpacking the product, check for any product damage that may have occurred during shipment and that the delivery is complete.

If the drive is damaged during shipping, contact the shipping insurance company or the carrier.

Accessories

After opening the shipping package and lifting the drive out, verify that the appropriate accessories were included in the delivery. The contents of the *accessories bag* differs by drive size and UL Type/IP protections class.



NOTE:
The accessories bag is located under the drive cover.

Size FS4

Table 5: Contents of Accessories Bag, FS4.

Item	Quantity	Purpose
M4 × 16 screw	11	Screws for power cable clamps (6), control cable clamps (3), grounding clamps (2)
M4 × 8 screw	1	Screw for optional grounding
M5 x 12 screw	1	Screw for drive external grounding
Control cable grounding lamella	3	Control cable grounding
EMC cable clamps, size M25	3	Clamping power cables
Grounding clamp	2	Power cable grounding
'Product modified' label	1	Information about modifications
Type 1/IP21: Cable grommet	3	Cable run-through sealing
Type 12/IP54: Cable grommet	6	Cable run-through sealing

Size FS5

Table 6: Contents of Accessories Bag, FS5.

Item	Quantity	Purpose
M4 × 16 screw	13	Screws for power cable clamps (6), control cable clamps (3), grounding clamps (4)
M4 × 8 screw	1	Screw for optional grounding
M5 × 12 screw	1	Screw for drive external grounding
Control cable grounding lamella	3	Control cable grounding
EMC cable clamps, size M32	2	Clamping power cables
Grounding clamp	2	Power cable grounding
'Product modified' label	1	Information about modifications
Type 1/IP21: Cable grommet, hole diameter 0.99 in. (25.3 mm)	1	Cable run-through sealing
Type 12/IP54: Cable grommet, hole diameter 0.99 in. (25.3 mm)	4	Cable run-through sealing
Cable grommet, hole diameter 1.3 in. (33.0 mm)	2	Cable run-through sealing



NOTE:
Dynamic braking and brake resistor is not supported in the BT300 Drive.

Size FS6

Table 7: Contents of Accessories Bag, FS6.

Item	Quantity	Purpose
M4 × 20 screw	10	Screws for power cable clamps (6) and grounding clamps (4)
M4 × 16 screw	3	Screws for control cable clamps
M4 × 8 screw	1	Screw for optional grounding
M5 × 12 screw	1	Screw for drive external grounding
Control cable grounding lamella	3	Control cable grounding
EMC cable clamps, size M40	2	Clamping power cables
Grounding clamp	2	Power cable grounding
'Product modified' label	1	Information about modifications
Cable grommet, hole diameter 1.3 in. (33.0 mm)	1	Cable run-through sealing
Cable grommet, hole diameter 1.6 in. (40.3 mm)	2	Cable run-through sealing
Type 12/IP54: Cable grommet, hole diameter 0.99 in. (25.3 mm)	3	Cable run-through sealing



NOTE:

Dynamic braking and brake resistor is not supported in the BT300 Drive.

Size FS7

Table 8: Contents of Accessories Bag, FS7.

Item	Quantity	Purpose
M6 × 30 slotted nut	6	Nuts for power cable clamps
M4 × 16 screw	3	Screws for control cable clamps
M6 × 12 screw	1	Screw for drive external grounding
Control cable grounding lamella	3	Control cable grounding
EMC cable clamps, size M50	3	Clamping power cables
Grounding clamp	2	Power cable grounding
'Product modified' label	1	Information about modifications
Cable grommet, hole diameter 1.98 in. (50.3 mm)	3	Cable run-through sealing
Type 12/IP54: Cable grommet, hole diameter 0.99 in. (25.3 mm)	3	Cable run-through sealing

Size FS8

Table 9: Contents of Accessories Bag, FS8.

Item	Quantity	Purpose
M4 × 16 screw	3	Screws for control cable clamps
Control cable grounding lamella	3	Control cable grounding
Cable lugs KP40	3	Clamping power cables
Cable insulator	11	Avoiding contact between cables
Cable grommet, hole diameter 0.99 in. (25.3 mm)	4	Control cable run-through sealing
IP00: Touch protection shield	1	Avoiding contact with live parts
IP00: M4 × 8 screw	2	Attaching the touch protection shield

Size FS9

Table 10: Contents of Accessories Bag, FS9.

Item	Quantity	Purpose
M4 × 16 screw	3	Screws for control cable clamps
Control cable grounding lamella	3	Control cable grounding
Cable lugs KP40	5	Clamping power cables
Cable insulator	10	Avoiding contact between cables
Cable grommet, hole diameter 0.99 in. (25.3 mm)	4	Control cable run-through sealing
IP00: Touch protection shield	1	Avoiding contact with live parts
IP00: M4 × 8 screw	2	Attaching the touch protection shield

Chapter 3 - Mounting

The drive must be mounted in the vertical position on the wall or on the back plane of an enclosure. Ensure that the flatness variation does not exceed 0.12 in (3 mm). If the conditions of the mounting place require horizontal mounting, the functionalities within the given nominal values stated in Chapter 7 - Technical data [→ 77] cannot be guaranteed.

Use the screws and other components included in the delivery to mount the drive.

Dimensions in Millimeters (Inches)

Wall Mount

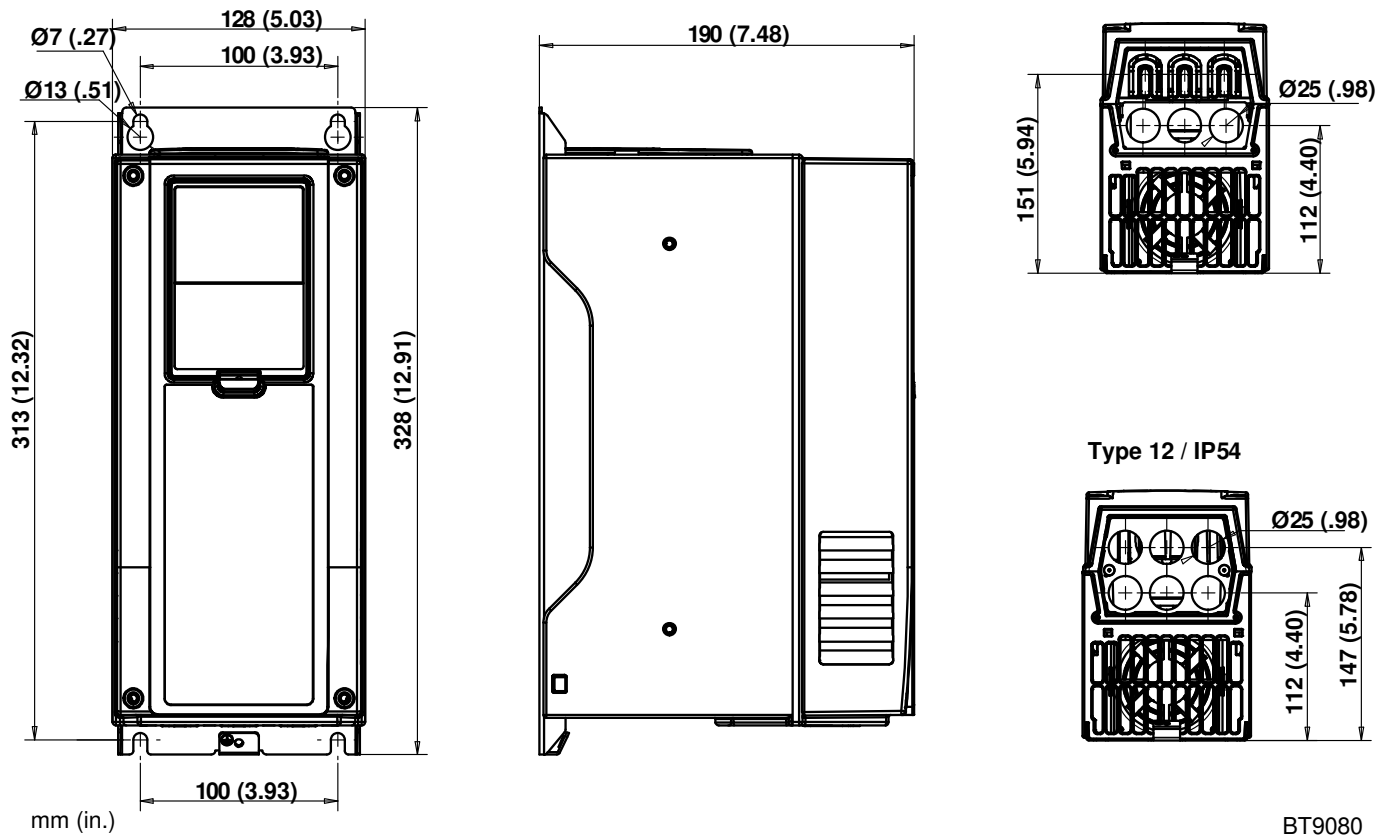

BT9080

Figure 2: Siemens BT300 HVAC Drive Dimensions, FS4, Wall Mount.

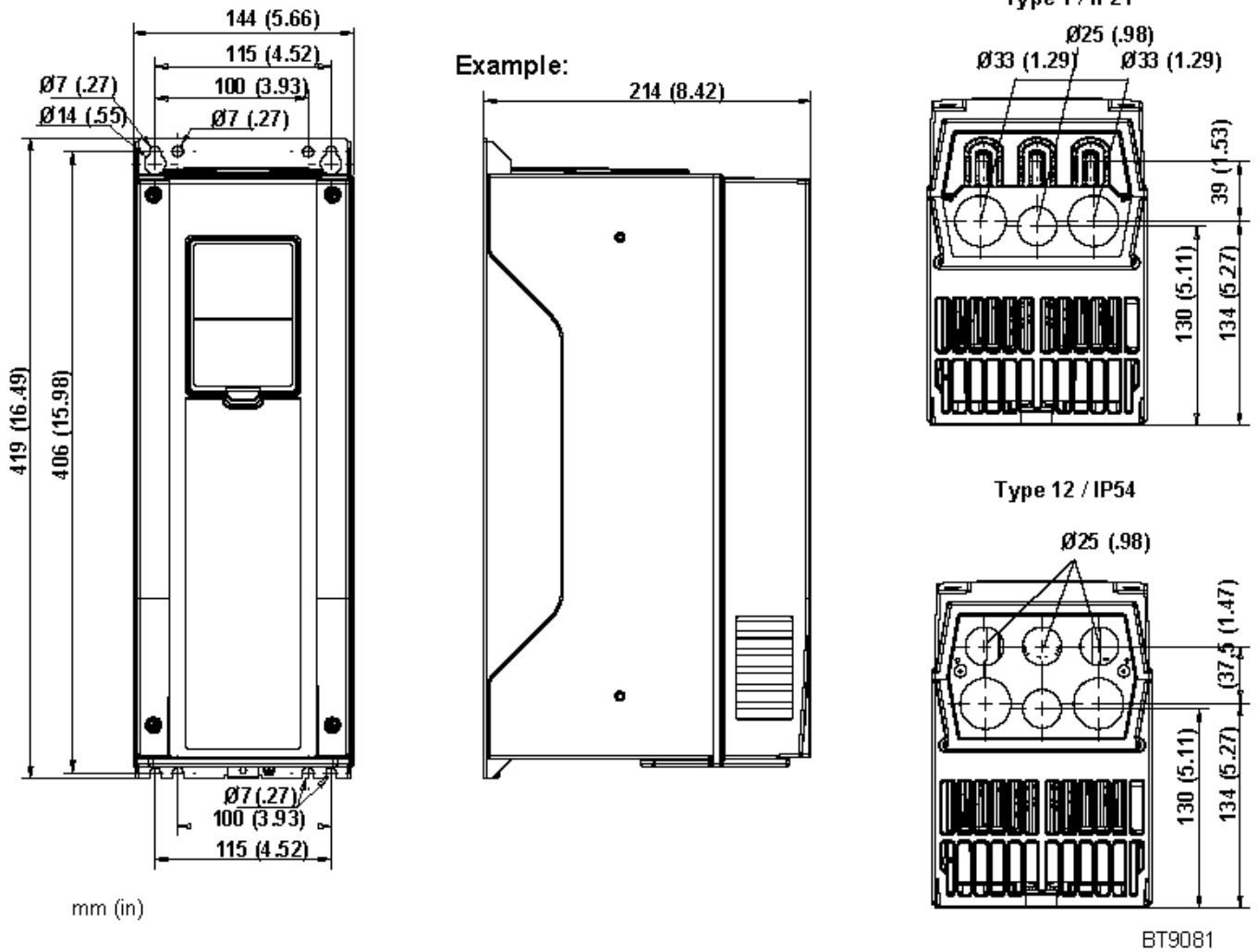

Figure 3: Siemens BT300 HVAC Drive Dimensions, FS5, Wall Mount.

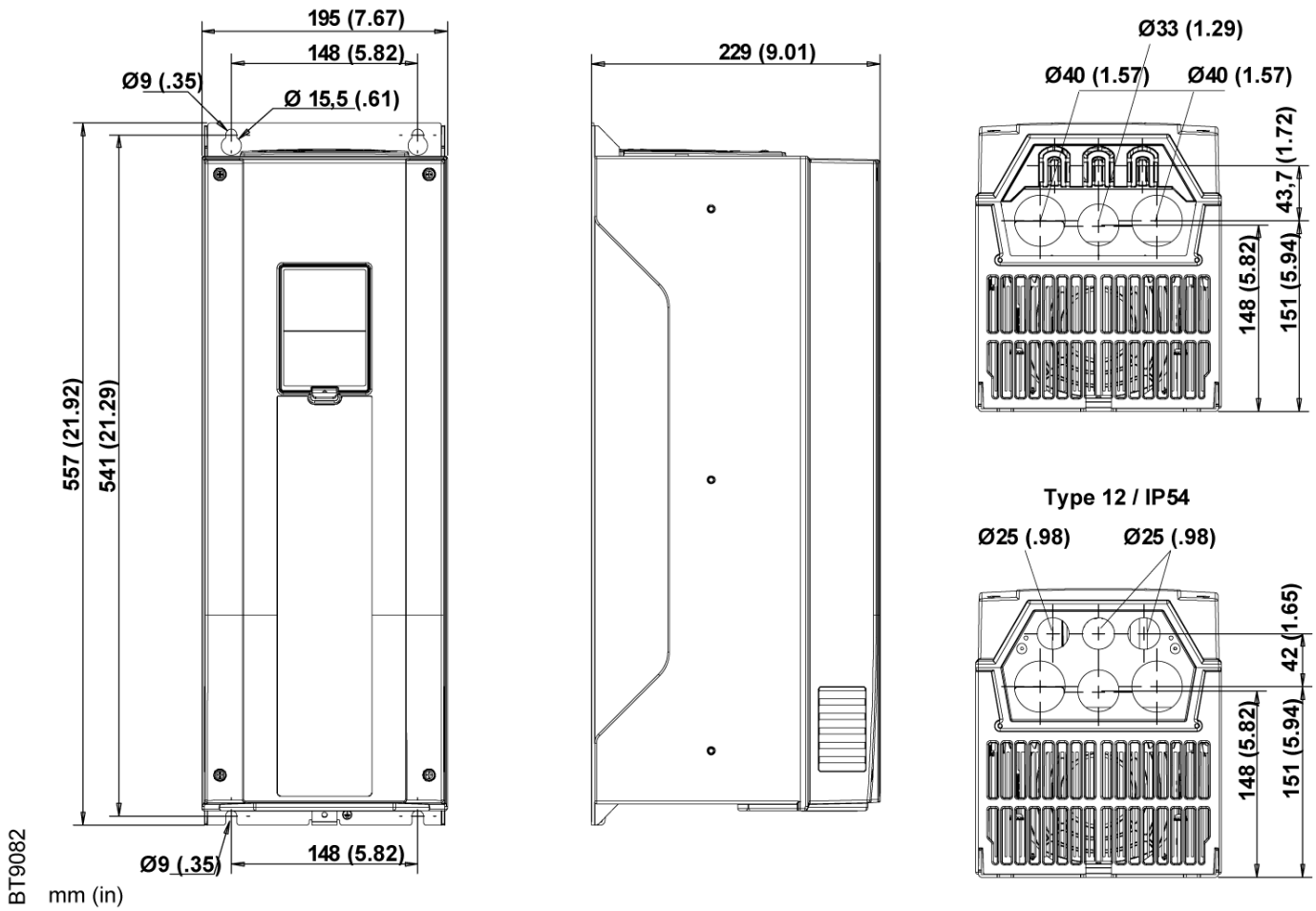

Figure 4: Siemens BT300 HVAC Drive Dimensions, FS6, Wall Mount.

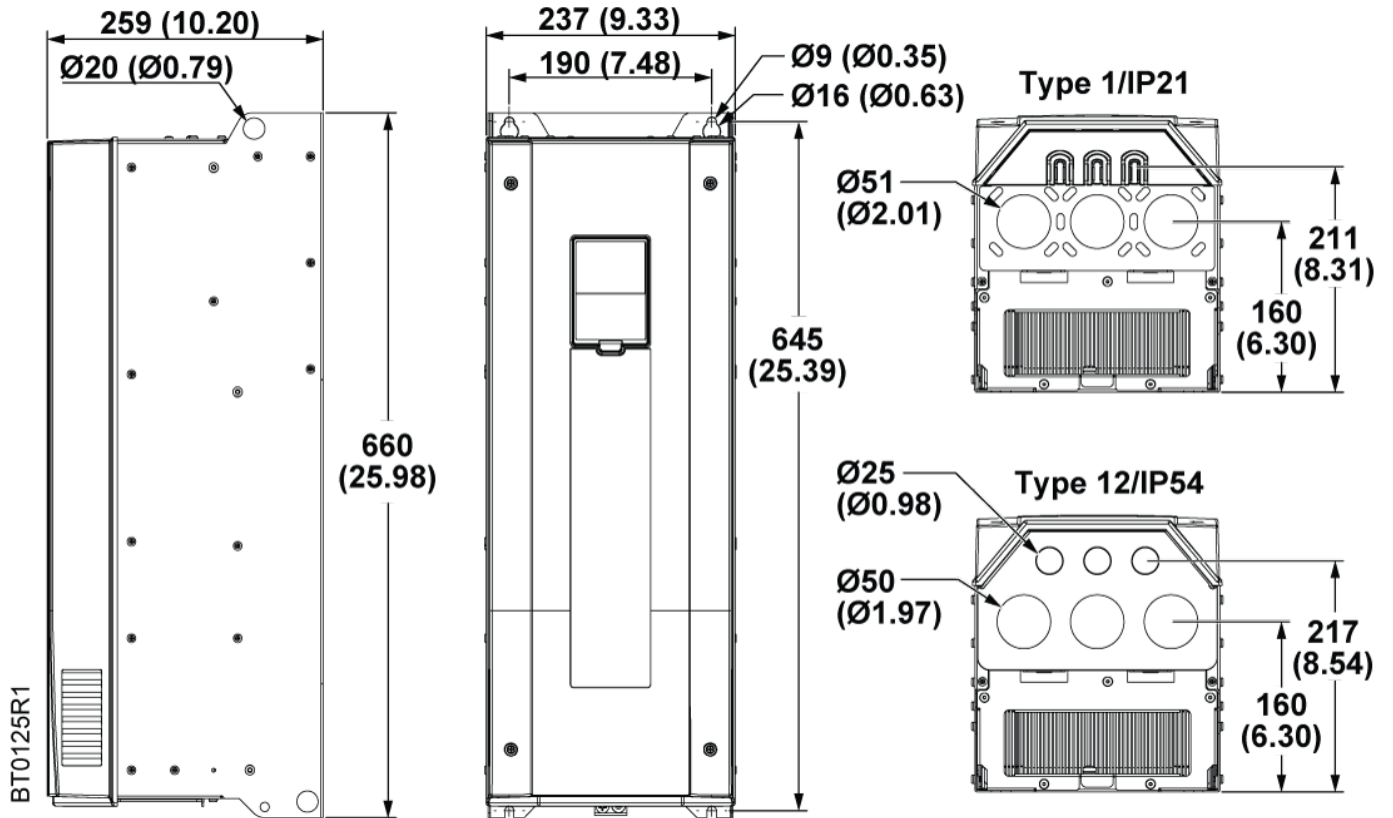

Figure 5: Siemens BT300 HVAC Drive Dimensions, FS7, Wall Mount.

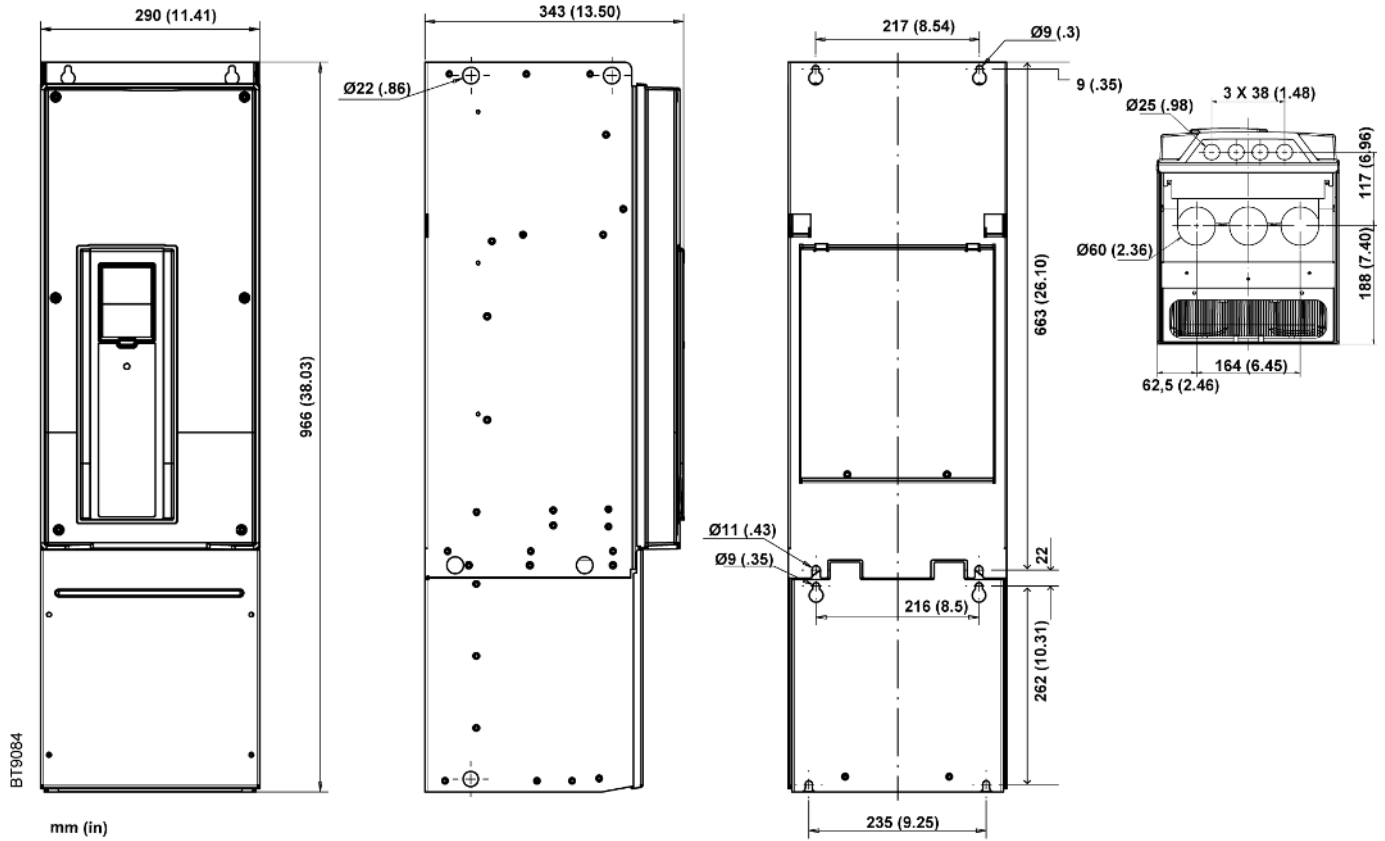

Figure 6: Siemens BT300 HVAC Drive Overall Dimensions, FS8 Type 1/IP21 and Type 12/IP54.

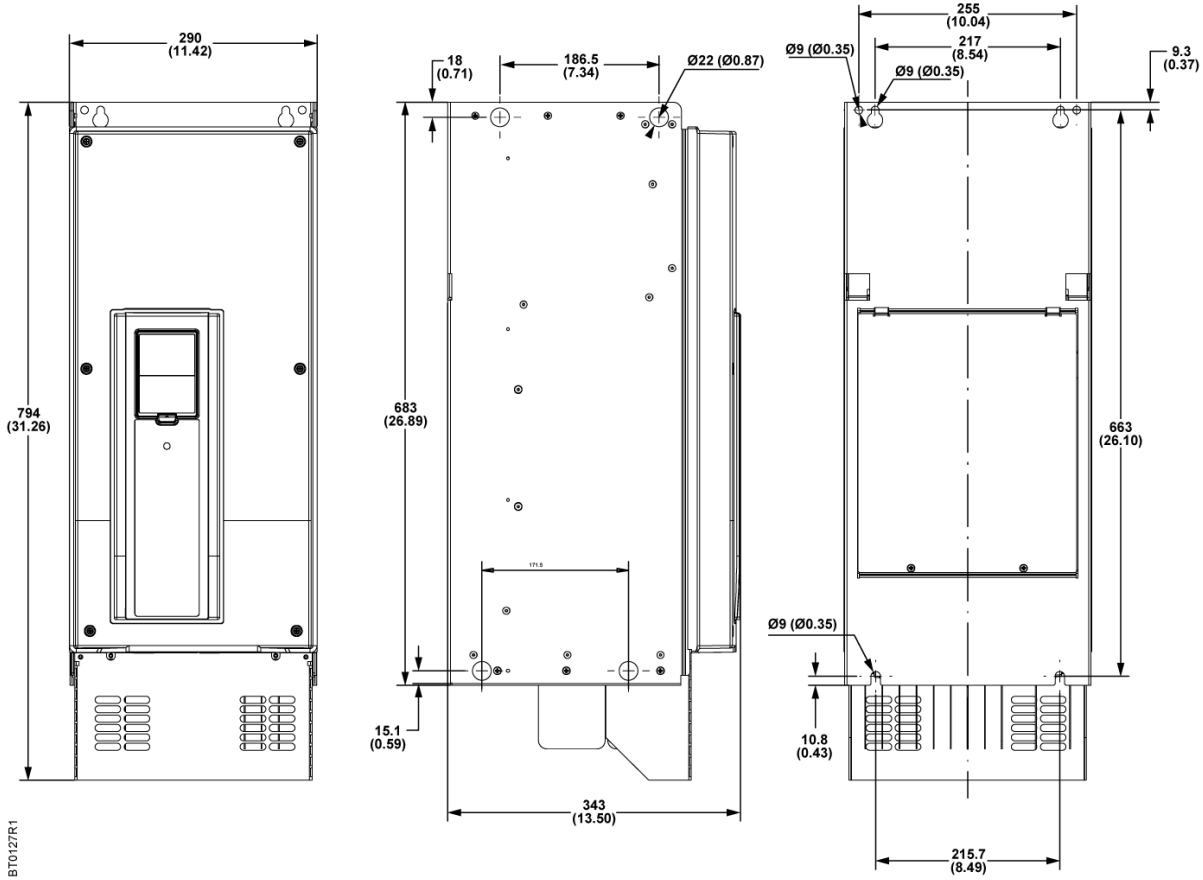

Figure 7: Siemens BT300 HVAC Drive Detailed Dimensions, FS8 Type 1/IP21 and Type 12/IP54.

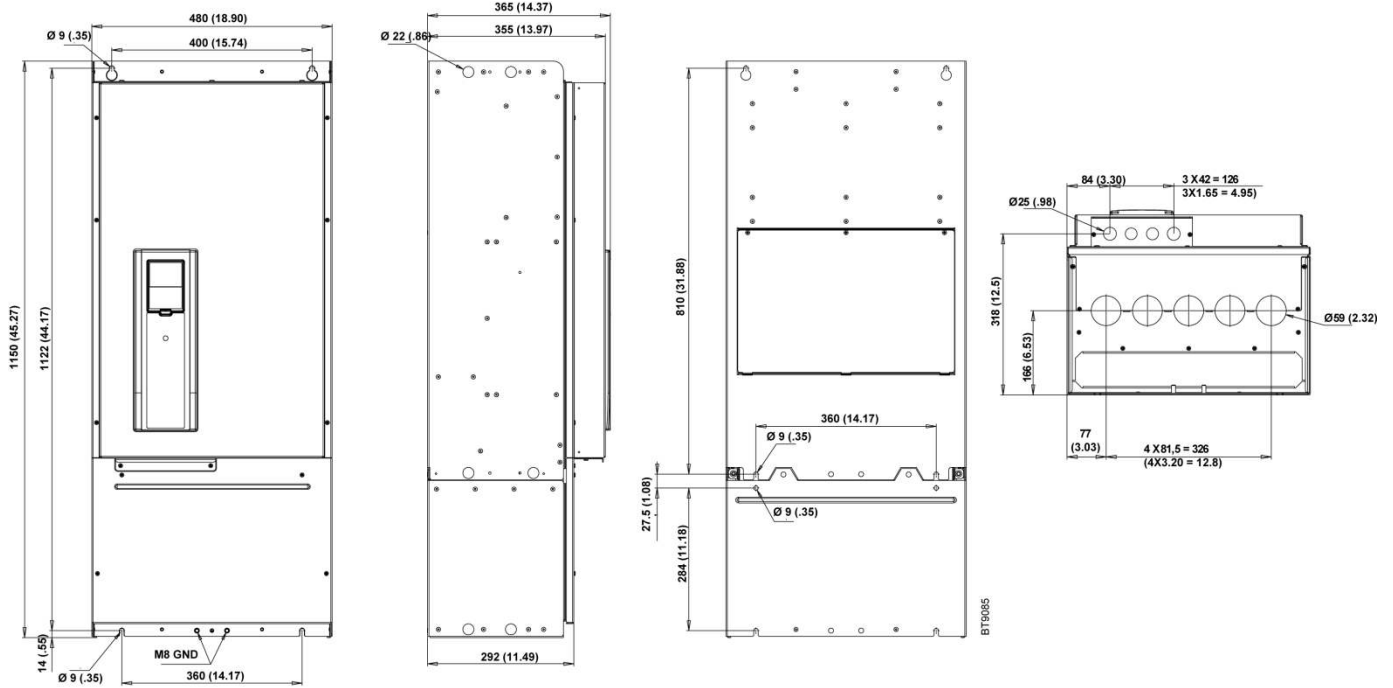

Figure 8: Siemens BT300 HVAC Drive Overall Dimensions, FS9 Type 1/IP21 and Type 12/IP54.

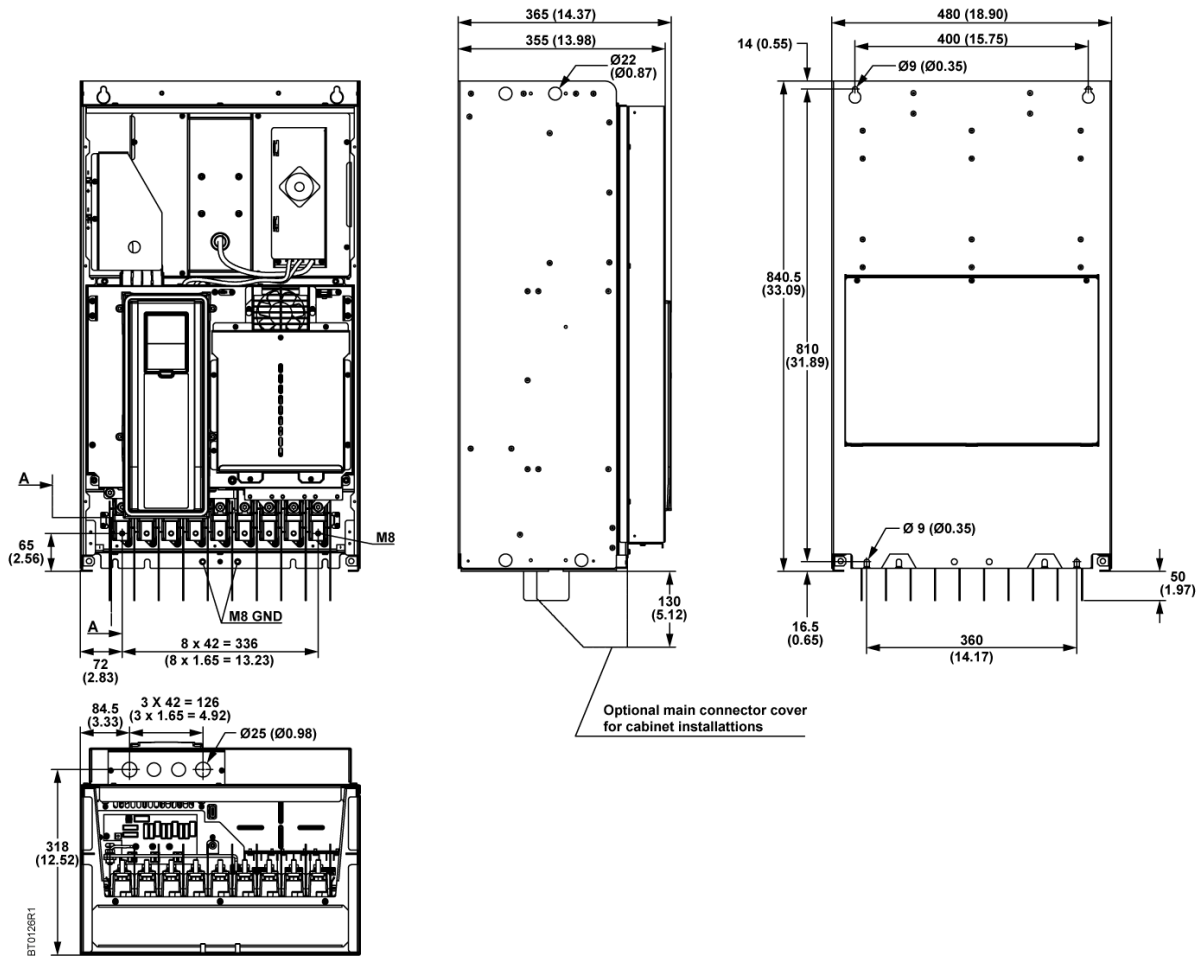

Figure 9: Siemens BT300 HVAC Drive Detailed Dimensions, FS9 Type 1/IP21 and Type 12/IP54.

Flange Mount

The drive can also be recessed into the cabinet wall or similar surface. A special *flange mount option* is available for this purpose. For further information see the *Siemens BT300 Flange Mount Kits for Frames FS4 to FS7 Mounting Instructions* (DPD01156).

Cooling

The drive produces heat when operating and is cooled down with air circulated by a fan. Ensure that enough free space is left around the drive for air circulation and cooling.

Ensure that the temperature of the cooling air does not exceed the maximum ambient operating temperature of the drive. See *Chapter 7 – Technical Data* for more information.

A	Clearance around the drive (see also B)
B	Distance from one drive to another or distance to cabinet wall
C	Free space above the drive
D	Free space below the drive

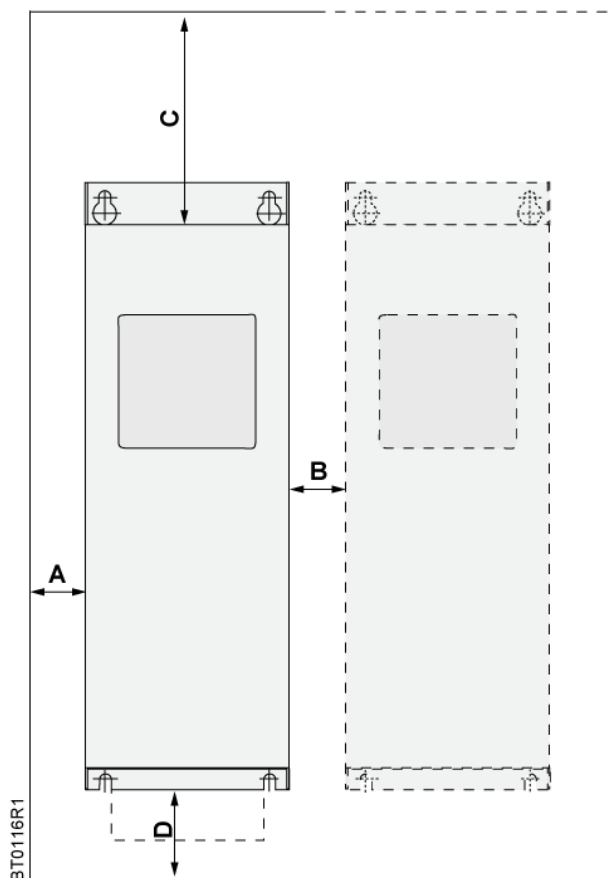

Figure 10: Installation Space.

Table 11: Minimum Clearances Around the Drive.

Minimum Clearance in Inches (mm).				
Type	A ¹	B ¹	C	D
FS4	0.78 (20)	0.78 (20)	3.93 (100)	1.96 (50)
FS5	0.78 (20)	0.78 (20)	4.72 (120)	2.36 (60)
FS6	0.78 (20)	0.78 (20)	6.29 (160)	3.14 (80)
FS7	0.78 (20)	0.78 (20)	9.84 (250)	3.93 (100)
FS8	0.78 (20)	0.78 (20)	11.8 (300)	5.90 (150)
FS9	0.78 (20)	0.78 (20)	13.8 (350)	7.87 (200)

- 1) Minimum clearances A and B for drives with UL Type 12/IP54 enclosure is **0 in. (0 mm)**.

Table 12: Required Cooling Air.

Type	Cooling Air Required in m ³ /h (ft ³ /h)
FS4	45 (1,589)
FS5	75 (2,647)
FS6	190 (6,710)
FS7	185 (6,533)
FS8	335 (11,830)
FS9	621 (21,930)



NOTE:

If several units are mounted **above** each other, the required free space equals C + D (see the following figure).

The outlet air used for cooling by the lower unit must be directed away from the air intake of the upper unit with a piece of metal plate mounted to the cabinet wall between the drives as shown in the following figure.

When planning the air circulation inside cabinets, recirculation of the air must be avoided.

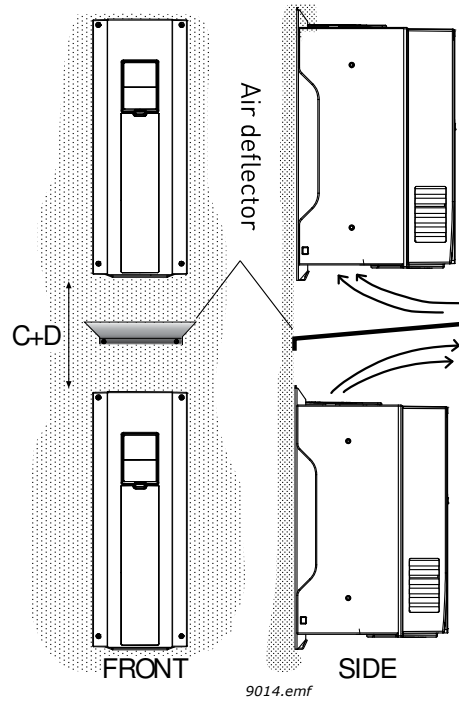

Figure 11: Installation Space When Drives are Mounted Above Each Other.

Chapter 4 - Power Cabling

The line voltage cables are connected to terminals L1, L2 and L3 and the motor cables to terminals marked with U, V and W. See the following figure. See Table *Cable Types Required to Meet Standards* for the cable recommendations for different EMC levels.

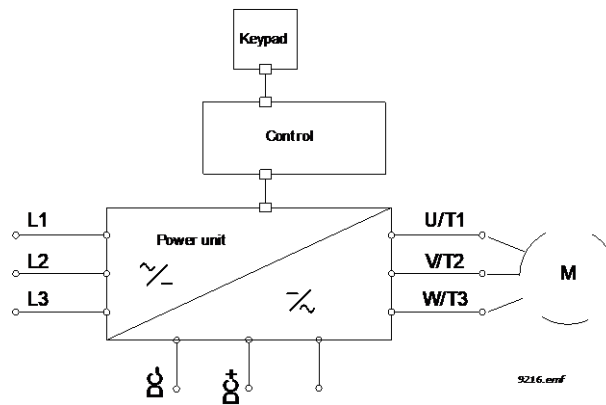

Figure 12: Connection Diagram.

Use cables with heat resistance of at least +70° C (158° F). The cables and the fuses must be sized according to the drive nominal OUTPUT current found on the nameplate.

Table 13: Cable Types Required to Meet EMC Standards.

Cable Type	EMC Levels		
	1 st Environment	2 nd Environment	
	Category C2	Category C3	Level C4
Line voltage cable	1	1	1
Motor cable	3*	2	2
Control cable	4	4	4

*360° grounding of the shield with cable glands in motor end needed for EMC level C2.

- 1 = Power cable intended for fixed installation and the specific line voltage. Shielded cable not required. (MCMK or similar recommended).
- 2 = Symmetrical power cable equipped with concentric protection wire and intended for the specific line voltage. (MCMK or similar recommended). See the following figure.
- 3 = Symmetrical power cable equipped with compact low-impedance shield and intended for the specific line voltage. [MCCMK, EMCCK or similar recommended; Recommended cable transfer impedance (1 to 30 MHz) max. 100mohm/m). See the following figure.
- 4 = Screened cable equipped with compact low-impedance shield (JAMAK, SAB/ÖZCuY-O or similar).

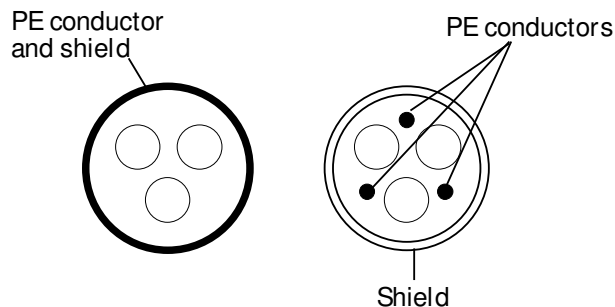

9007.emf

Figure 13: Conductor Cross-sections.



NOTES:

The factory-default switching frequencies (all frames) meet EMC requirements. If the safety switch is connected, the EMC protection is continuous over the entire cable installation.

UL Criteria for Cabling and Fusing

Cable Dimensioning

The cable dimensioning in *Table Cable and Fuse Sizes for Siemens BT300 (FS4 to FS9)* is in accordance with UL61800-5-1, and the National Electric Code per table 310.15(B)(16). The values were determined for UL-approved copper wire using correction factors for a 40° C ambient operating temperature, while using AC drive cables with a minimum insulation rating of 60° C /75° C. See local or municipal regulations for more sizing requirements.



NOTE:

The data detailed within Table Cable and Fuse Sizes for Siemens BT300 (FS4 to FS9) applies to cases with one motor and one cable connection from the AC drive to the motor. In other applications, consult the factory for more information.

Fuse Sizing

The AC drive is suitable for use on a circuit capable of delivering not more than 100,000 rms symmetrical amperes (600V maximum) when protected by UL-listed Type J or T fuses. The fuse voltage rating should be selected according to the supply network. The final selection should be in accordance with the local or municipal regulations, cable specifications and cable installation conditions.

Table 14: Cable and Fuse Sizes for Siemens BT300 (FS4 to FS9).

Frame	Type	I _L [A]	Fuse (Class J/T) [A]	Line, Motor and Ground Cable Cu	Terminal Cable Size	
					Main	Ground
FS4	BT300-001X2...	4.2	6	AWG14	AWG24 - AWG10	AWG17 - AWG10
	BT300-00152...	6.0	6	AWG14	AWG24 - AWG10	AWG17 - AWG10
	BT300-002X2...	7.2	10	AWG14	AWG24 - AWG10	AWG17 - AWG10
	BT300-003X2...	9.7	15	AWG14	AWG24 - AWG10	AWG17 - AWG10
	BT300-00154...	3.4	6	AWG14	AWG24 - AWG10	AWG17 - AWG10
	BT300-002X4...	4.6	6	AWG14	AWG24 - AWG10	AWG17 - AWG10
	BT300-003X4...	5.4	10	AWG14	AWG24 - AWG10	AWG17 - AWG10
	BT300-005X4...	9.3	15	AWG14	AWG24 - AWG10	AWG17 - AWG10
	BT300-00754...	11.3	20	AWG14	AWG24 - AWG10	AWG17 - AWG10
FS5	BT300-005X2...	16.1	25	AWG10	AWG20 - AWG5	AWG17 - AWG8
	BT300-00752...	21.7	30	AWG10	AWG20 - AWG5	AWG17 - AWG8
	BT300-010X2...	27.7	40	AWG8	AWG20 - AWG5	AWG17 - AWG8
	BT300-010X4...	15.4	25	AWG10	AWG20 - AWG5	AWG17 - AWG8
	BT300-015X4...	21.3	30	AWG10	AWG20 - AWG5	AWG17 - AWG8
	BT300-020X4...	28.4	40	AWG8	AWG20 - AWG5	AWG17 - AWG8
	BT300-003X6...	3.9	6	AWG14	AWG20 - AWG5	AWG17 - AWG8
	BT300-005X6...	6.1	10	AWG 14	AWG20 - AWG5	AWG17 - AWG8
	BT300-00756...	9.0	10	AWG14	AWG20 - AWG5	AWG17 - AWG8
	BT300-010X6...	11.0	15	AWG14	AWG20 - AWG5	AWG17 - AWG8
	FS6	BT300-015X2...	43.8	60	AWG4	AWG13 - AWG0
BT300-020X2...		57.0	80	AWG4	AWG13 - AWG0	AWG13 - AWG2
BT300-025X4...		36.7	50	AWG4	AWG13 - AWG0	AWG13 - AWG2
BT300-030X4...		43.6	60	AWG4	AWG13 - AWG0	AWG13 - AWG2
BT300-040X4...		58.2	80	AWG4	AWG13 - AWG0	AWG13 - AWG2
BT300-015X6...		18.0	20	AWG10	AWG13 - AWG0	AWG13 - AWG2
BT300-020X6...		22.0	25	AWG10	AWG13 - AWG0	AWG13 - AWG2
BT300-025X6...		27.0	30	AWG8	AWG13 - AWG0	AWG13 - AWG2
BT300-030X6...		34.0	40	AWG8	AWG13 - AWG0	AWG13 - AWG2

Frame	Type	I _L [A]	Fuse (Class J/T) [A]	Line, Motor and Ground Cable Cu	Terminal Cable Size	
					Main	Main
FS7	BT300-025X2...	69.0	100	AWG2	AWG9 - AWG2/0	AWG9 - AWG2/0
	BT300-030X2...	82.1	110	AWG1	AWG9 - AWG2/0	AWG9 - AWG2/0
	BT300-040X2...	99.0	150	AWG1/0	AWG9 - AWG2/0	AWG9 - AWG2/0
	BT300-050X4...	67.5	100	AWG2	AWG9 - AWG2/0	AWG9 - AWG2/0
	BT300-060X4...	85.3	110	AWG1	AWG9 - AWG2/0	AWG9 - AWG2/0
	BT300-075X4...	100.6	150	AWG1/0	AWG9 - AWG2/0	AWG9 - AWG2/0
	BT300-040X6...	41.0	50	AWG6	AWG9 - AWG2/0	AWG9 - AWG2/0
	BT300-050X6...	52.0	60	AWG6	AWG9 - AWG2/0	AWG9 - AWG2/0
	BT300-060X6...	62.0	70	AWG4	AWG9 - AWG2/0	AWG9 - AWG2/0
FS8	BT300-050X2...	135.1	200	AWG3/0	AWG1 - 350 kcmil	AWG1 - 350 kcmil
	BT300-060X2...	162.0	225	250 kcmil	AWG1 - 350 kcmil	AWG1 - 350 kcmil
	BT300-075X2...	200.0	250	350 kcmil	AWG1 - 350 kcmil	AWG1 - 350 kcmil
	BT300-100X4...	139.4	200	AWG3/0	AWG1 - 350 kcmil	AWG1 - 350 kcmil
	BT300-125X4...	166.5	225	250 kcmil	AWG1 - 350 kcmil	AWG1 - 350 kcmil
	BT300-150X4...	199.6	250	350 kcmil	AWG1 - 350 kcmil	AWG1 - 350 kcmil
	BT300-075X6...	80.0	90	AWG1/0	AWG1 - 350 kcmil	AWG1 - 350 kcmil
	BT300-100X6...	100.0	110	AWG1/0	AWG1 - 350 kcmil	AWG1 - 350 kcmil
	BT300-125X6...	125.0	150	AWG1/0	AWG1 - 350 kcmil	AWG1 - 350 kcmil
FS9	BT300-100X2...	253.0	350	2*250 kcmil	AWG1 - 350 kcmil	AWG1 - 350 kcmil
	BT300-125X2...	301.0	400	2*350 kcmil	AWG1 - 350 kcmil	AWG1 - 350 kcmil
	BT300-200X4...	258.0	350	2*250 kcmil	AWG1 - 350 kcmil	AWG1 - 350 kcmil
	BT300-250X4...	303.0	400	2*350 kcmil	AWG1 - 350 kcmil	AWG1 - 350 kcmil
	BT300-150X6...	144.0	175	AWG3/0	AWG1 - 350 kcmil	AWG1 - 350 kcmil
	BT300-200X6...	208.0	250	300 kcmil	AWG1 - 350 kcmil	AWG1 - 350 kcmil



NOTES:

1. Only use cables with concentric copper shield; maximum number of parallel cables is 9.
2. When using cables in parallel, the requirements of both the cross-sectional area and the maximum number of cables must be observed.

For important information on the requirements of the grounding conductor, see standard Underwriters' Laboratories UL508C. For the correction factors for each temperature, see the instructions of standard Underwriters' Laboratories UL508C.

Cable Installation

- Before starting, check that none of the components of the drive is live. Carefully read the warnings in Chapter 1.
- Place the motor cables sufficiently far from other cables

- Avoid placing the motor cables in long parallel lines with other cables.
- If the motor cables run in parallel with other cables note the minimum distances between the motor cables and other cables given in the following table.

Distance Between Cables, m (ft)	Shielded Cable, m (ft)
1.0 (0.3)	≤ 164 (50)
3.2 (1.0)	≥ 656 (200)

- The given distances also apply between the motor cables and signal cables of other systems.
- The maximum lengths of motor cables (shielded) are:
 - 328 ft (100 m) (FS4)
 - 493 ft (150 m) (FS5 and FS6)
 - 656 ft (200 m) (FS7 to FS9).
- The motor cables should cross other cables at an angle of 90 degrees.
- If cable insulation checks are needed, see the *Cable and motor insulation checks* section [→ 67].

Start the cable installation according to the instructions in the following section.

Frames FS4 to FS7

1. Strip the motor and line voltage (mains) cables as outlined in the following figure and table.

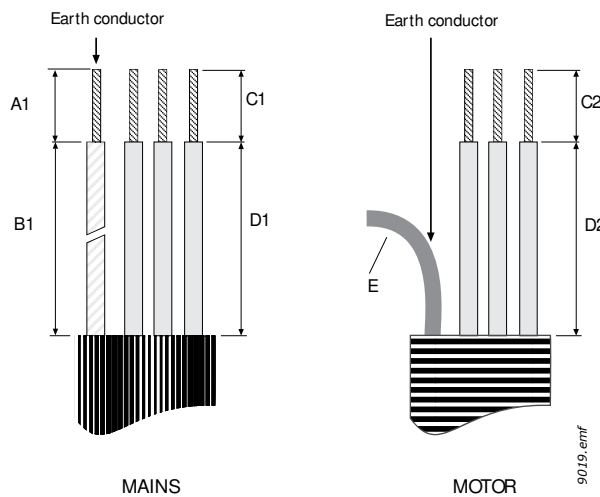

Figure 14: Stripping the Cables.

Table 15: Cable Stripping Lengths in Inches (mm).

Frame	A1	B1	C1	D1	C2	D2	E
FS4	0.59 (15)	1.38 (35)	0.39 (10)	0.78 (20)	0.27 (7)	1.38 (35)	Leave as short as possible
FS5	0.78 (20)	1.57 (40)	0.39 (10)	1.18 (30)	0.39 (10)	1.57 (40)	
FS6	0.78 (20)	3.54 (90)	0.59 (15)	2.36 (60)	0.59 (15)	2.36 (60)	
FS7	0.78 (20)	3.15 (80)	0.78 (20)	3.15 (80)	0.78 (20)	3.15 (80)	

2. Open the drive cover.

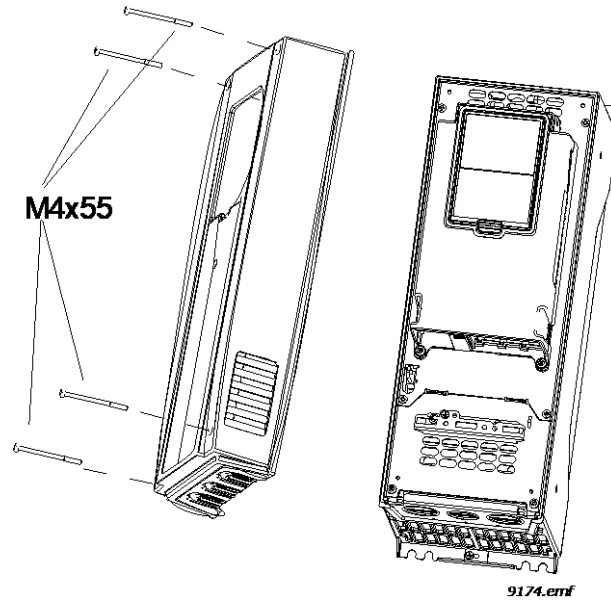

Figure 15: Opening Cover.

3. **Remove the screws** of the cable protection plate. Do not open the cover of the power unit.

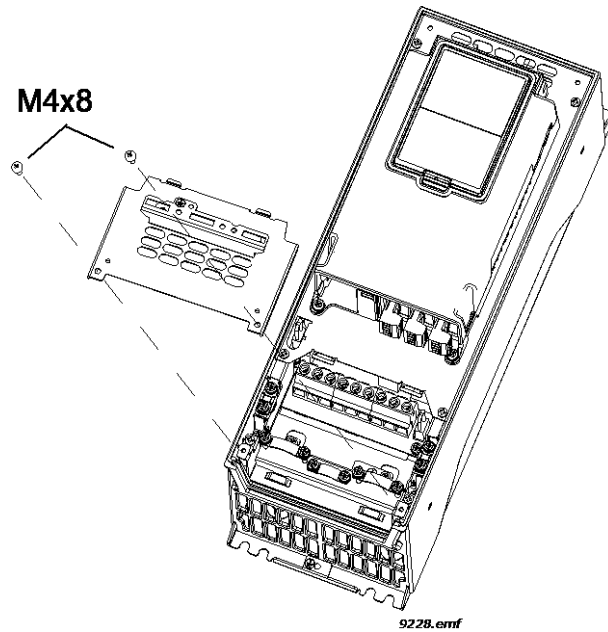

Figure 16: Removing screws

4. Insert the cable grommets (included in the delivery) in the openings of the cable entry plate (included).
5.
 - Insert the cables - supply cable and motor cable - in the openings of the cable entry plate.
 - Then cut the rubber grommets open to slide the cables through. Should the grommets fold in while inserting the cable, just draw the cable back a bit to straighten the grommets up.
 - Do not cut the grommet openings wider than what is necessary for the cables you are using.
6. Detach the cable clamps and the grounding clamps and then place the cable entry plate with the cables in the groove on the drive frame. See the following figures.

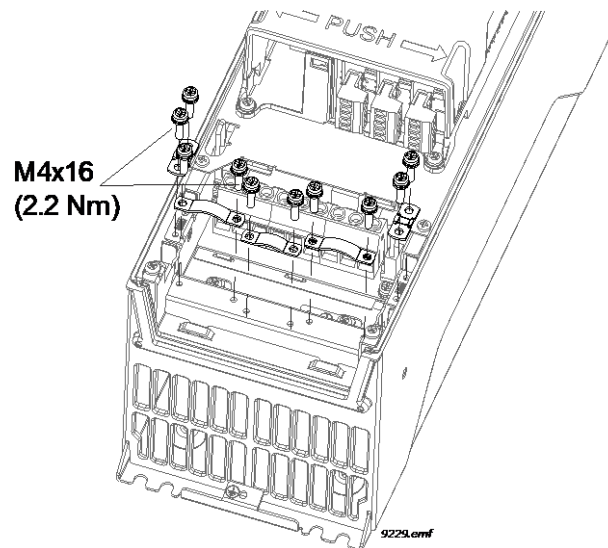
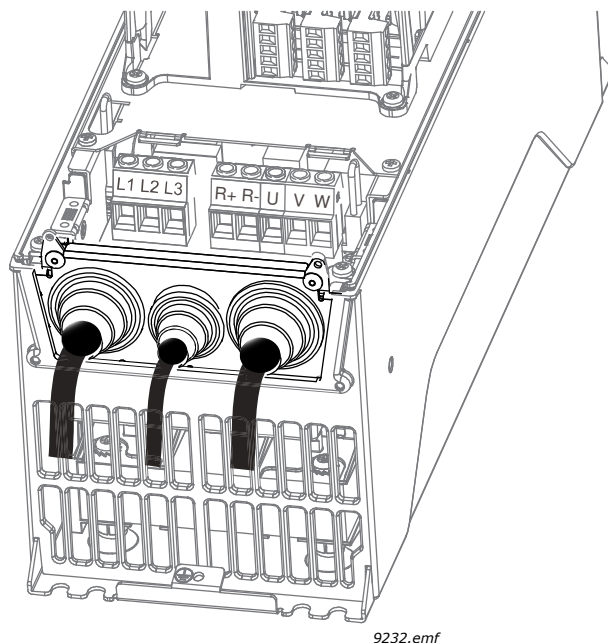

Figure 17: Detaching Cable Clamps.



9232.emf

Figure 18: Cable Entry Plate and Cables.

7. Connect the stripped cables (see Figure 18 [→ 33] and Table [→ 33]17) as shown in Figure 25 [→ 33].
 - Expose the shield of all three cables in order to make a 360-degree connection with the cable clamp (1).
 - Connect the (phase) conductors of the supply and motor cables into their respective terminals (2).

Form the rest of the cable shield of all three cables into “pigtailed” and make a grounding connection with a clamp as shown in Figure 25 [→ 33] (3). Make the pigtailed **just long enough** to reach and be attached to the terminal - not longer.

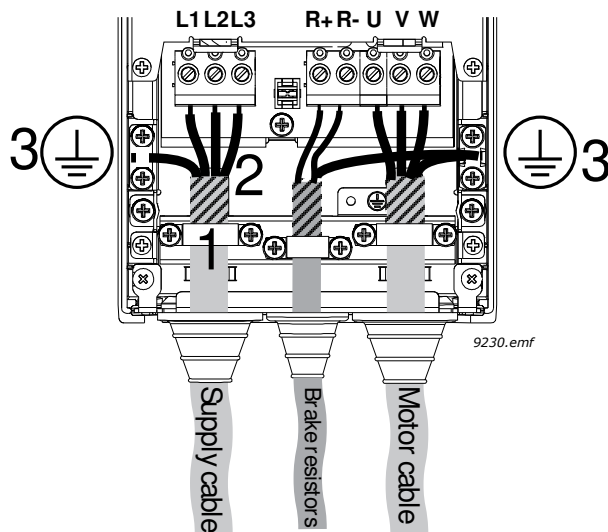

9230.emf

Figure 19: Cable Connection.

Tightening Torques of Cable Terminals:

Table 16: Tightening Torques of Terminals.

Frame	Product Number	Maximum Tightening Torque Nm/lb-in.					
		Power and Motor Terminals		EMC Grounding Clamps		Grounding Terminals	
		Nm	lb-in.	Nm	lb-in.	Nm	lb-in.
FS4	BT300-001X2...	0.6	5.3	1.5	13.3	2.0	17.7
	BT300-00152...						
	BT300-002X2...						
	BT300-003X2...						
	BT300-00154...						
	BT300-002X4...						
	BT300-003X4...						
	BT300-005X4...						
	BT300-00754...						

Frame	Product Number	Maximum Tightening Torque Nm/lb-in.					
		Power and Motor Terminals		EMC Grounding Clamps		Grounding Terminals	
		Nm	lb-in.	Nm	lb-in.	Nm	lb-in.
FS5	BT300-005X2...	1.5	13.3	1.5	13.3	2.0	17.7
	BT300-00752...						
	BT300-010X2...						
	BT300-010X4...						
	BT300-015X4...						
	BT300-020X4...						
	BT300-003X6...						
	BT300-005X6...						
	BT300-00756...						
	BT300--010X6...						
FS6	BT300-015X2...	10	88.5	1.5	13.3	2.0	17.7
	BT300-020X2...						
	BT300-025X4...						
	BT300-030X4...						
	BT300-040X4...						
	BT300-015X6...						
	BT300-020X6...						
	BT300-025X6...						
	BT300-030X6...						
	FS7						
BT300-030X2...							
BT300-040X2...							
BT300-050X4...							
BT300-060X4...							
BT300-075X4...							
BT300-040X6...							
BT300-050X6...							
BT300-060X6...							

8. Check the connection of the ground cable to the motor and the drive terminals marked with .



NOTE :

Two protective conductors are required according to standard EN 61800-5-1. See Figure 26 [→ 33] and chapter *Grounding and ground fault protection*. Use an M5 size screw and tighten it to 2.0 Nm (17.7 lb-in.).

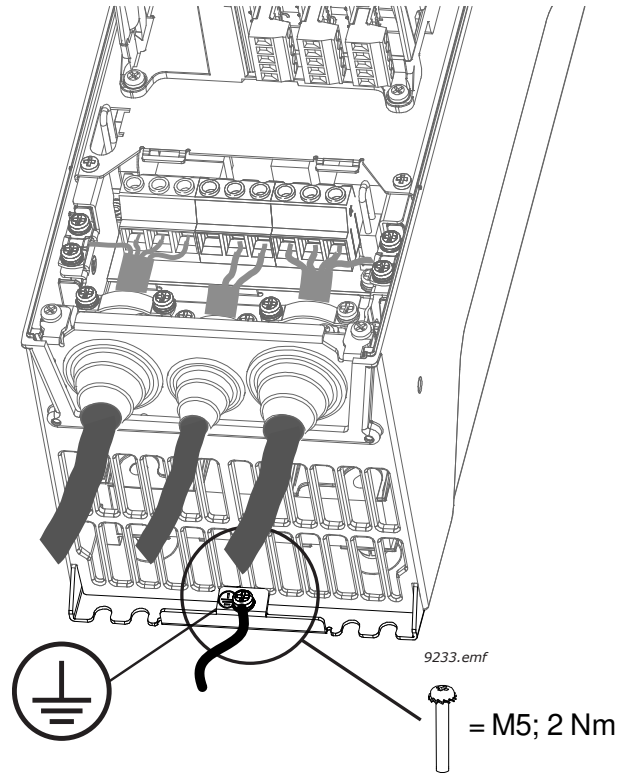

Figure 20: Additional Protective Grounding Connector.

9. Re-mount the cable protection plate (Figure 27 [→ 33]) and the cover of the drive.

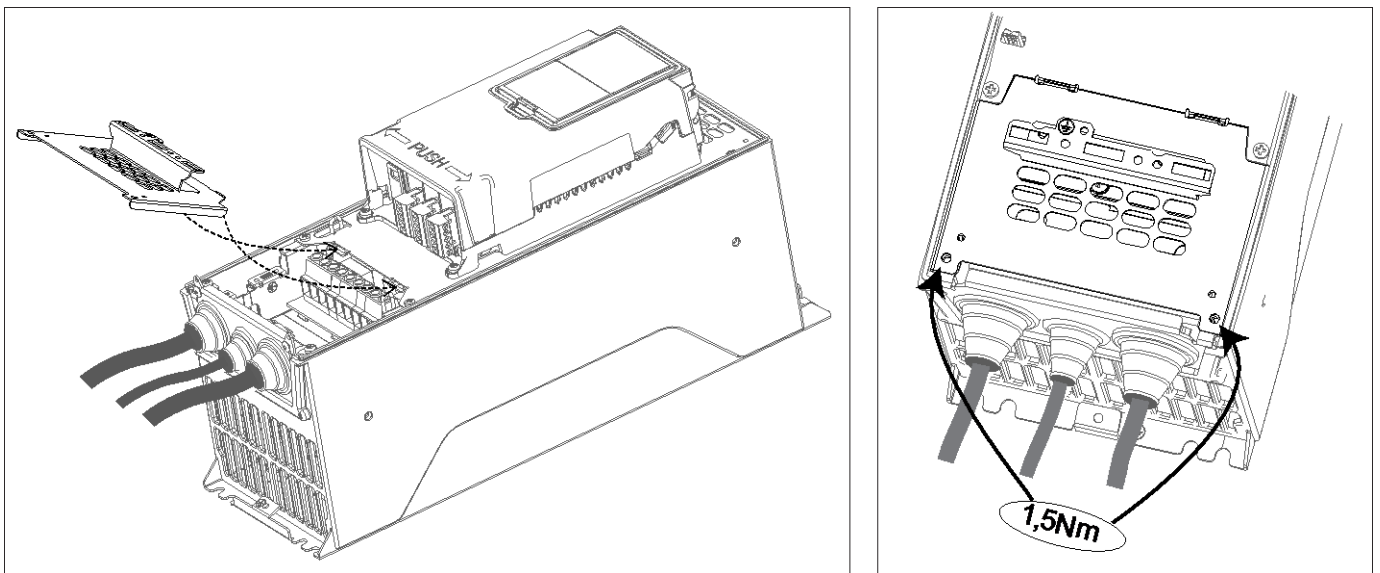

Figure 21: Re-mounting the Cover Components.

9234.emf

Frames FS8 and FS9

- Strip the motor and line voltage (mains) cables as outlined in the following figure and table.

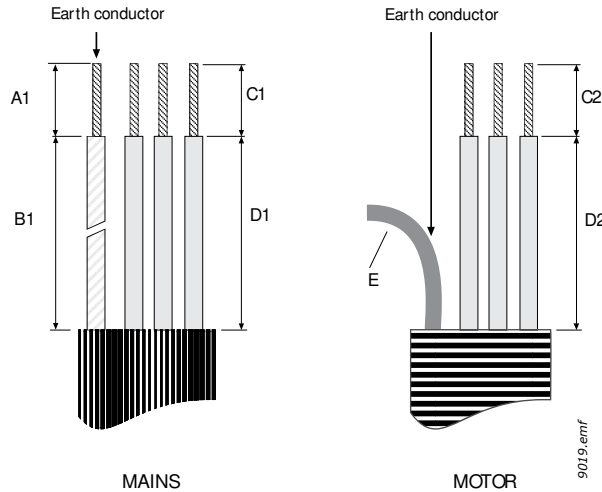

Figure 22: Stripping the Cables.

Table 17: Cable Stripping Lengths in Inches (mm).

Frame	A1	B1	C1	D1	C2	D2	E
FS8	1.57 (40)	7.08 (180)	0.98 (25)	11.8 (300)	0.98 (25)	11.8 (300)	Leave as short as possible
FS9	1.57 (40)	7.08 (180)	0.98 (25)	11.8 (300)	0.98 (25)	11.8 (300)	

- FS9 only:** Remove the main cover of the drive.

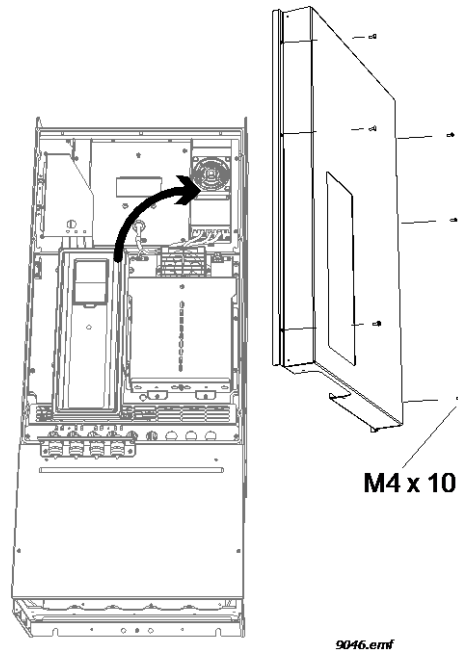

Figure 23: Removing the Main Cover (FS9 Only).

3. Remove the cable cover (1) and the cable fitting plate (2).

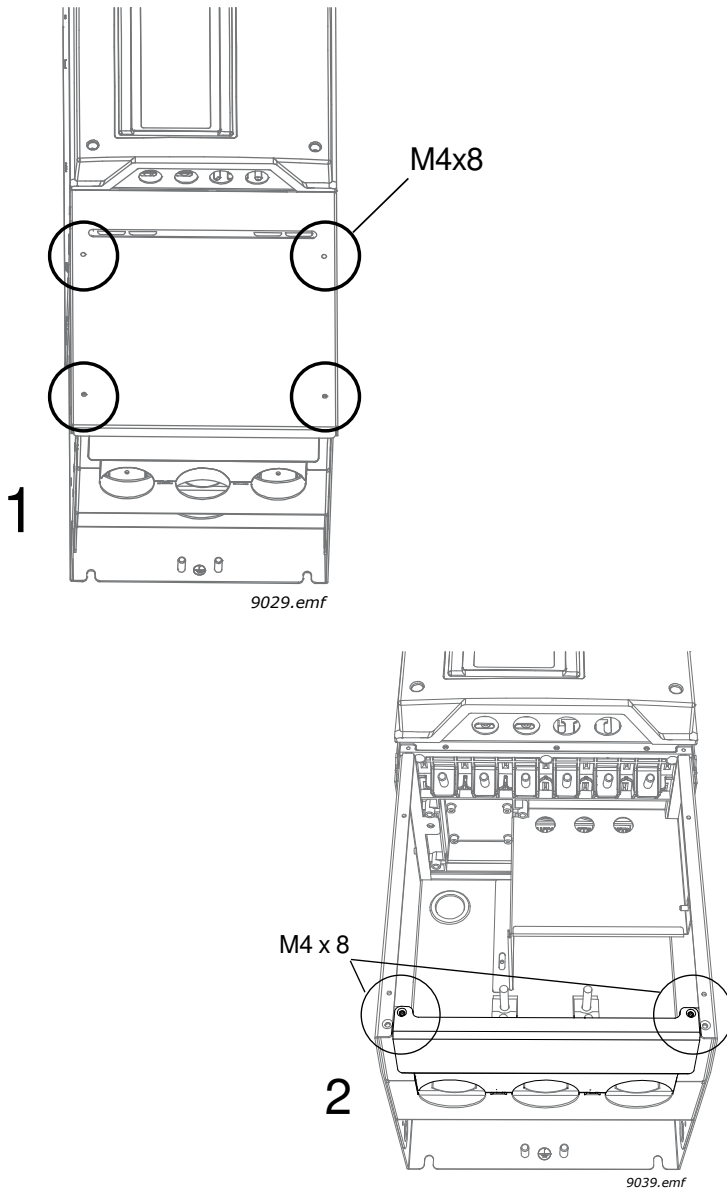

Figure 24: Removing the Cable Cover and Cable Fitting Plate (FS8).

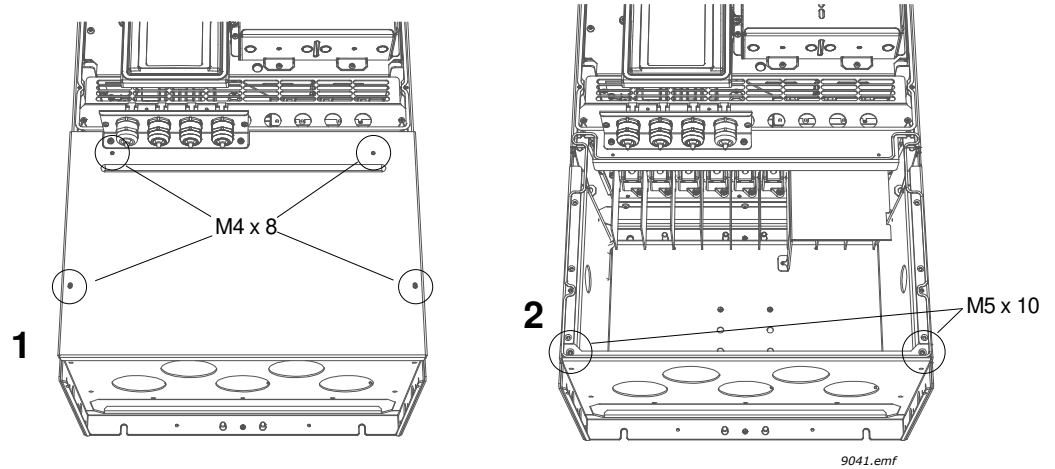

Figure 25: Removing the Cable Cover and Cable Fitting Plate (FS9).

4. **FS9 only:** Loosen the screws and remove the sealing plate.

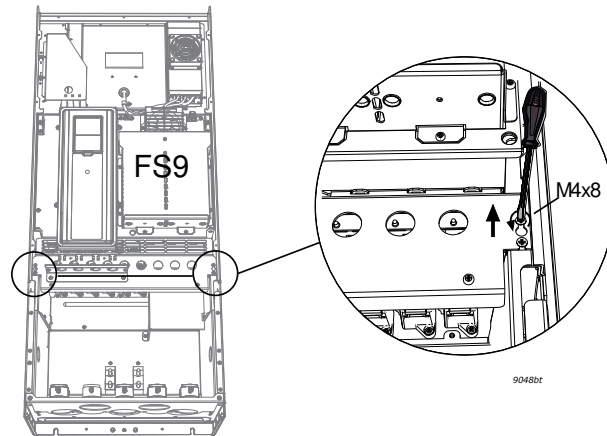

Figure 26: Removing the Sealing Plate (FS9).

5. Remove the EMC shield plate.

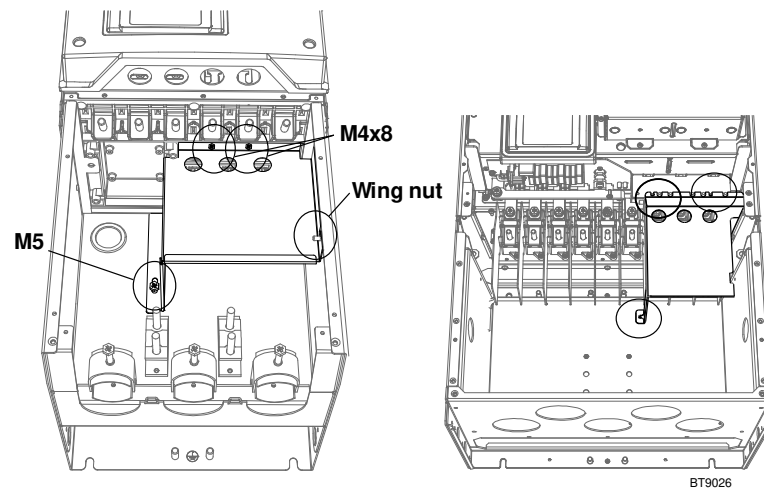

Figure 27: Removing EMC Shield Plate; Left: FS8, Right: FS9.

6. Locate the terminals.

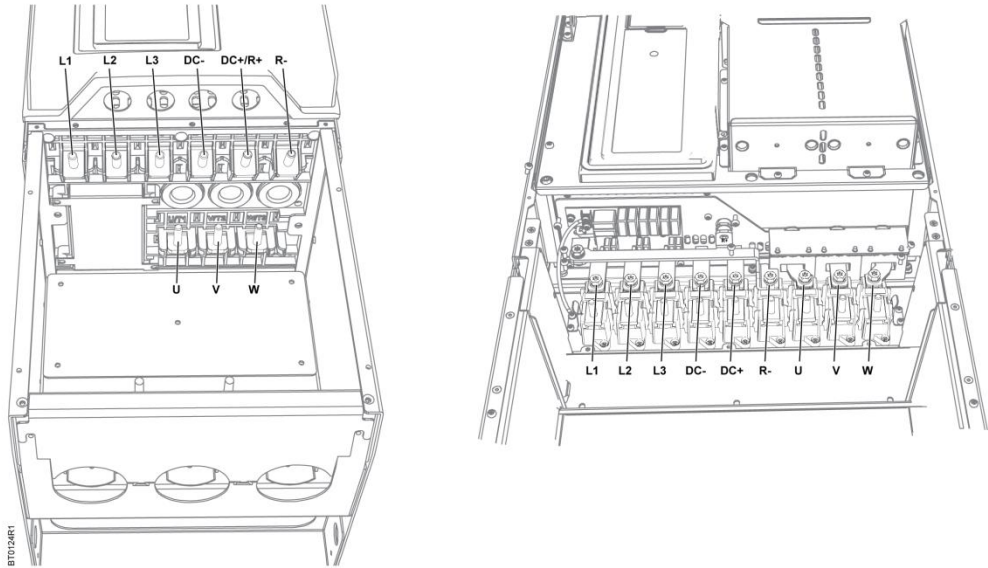

Figure 28: Power Terminals: Left: FS8, Right FS9.

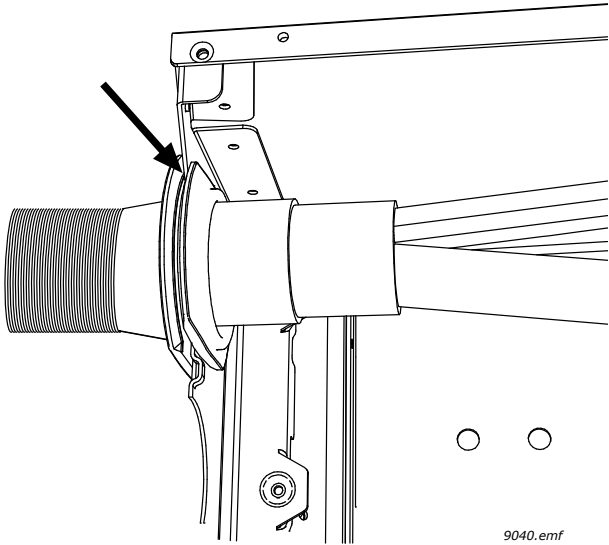

Figure 29: Placing the Grommet.

7. If you use thick cables, insert the cable insulators in between the terminals to avoid contact between the cables.

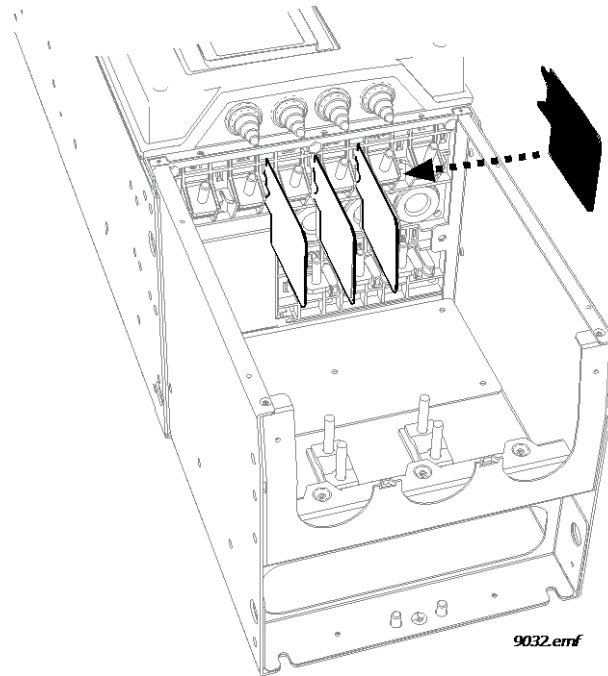

Figure 30: Inserting the Cable Insulators.

8. Connect the stripped cables as shown in the following figure.
 - a. Connect the (phase) conductors of the supply and motor cables into their respective terminals.
 - b. Form the rest of the cable shield of all cables into “pigtailed” and make a grounding connection as shown in Figure 38 [→ 40] (b) using the clamp from the *Accessories bag*.



NOTE :

If you use several cables on one connector, observe the position of cable lugs. See the following Figure *Placing Two Cable Lugs on Top of Each Other*.

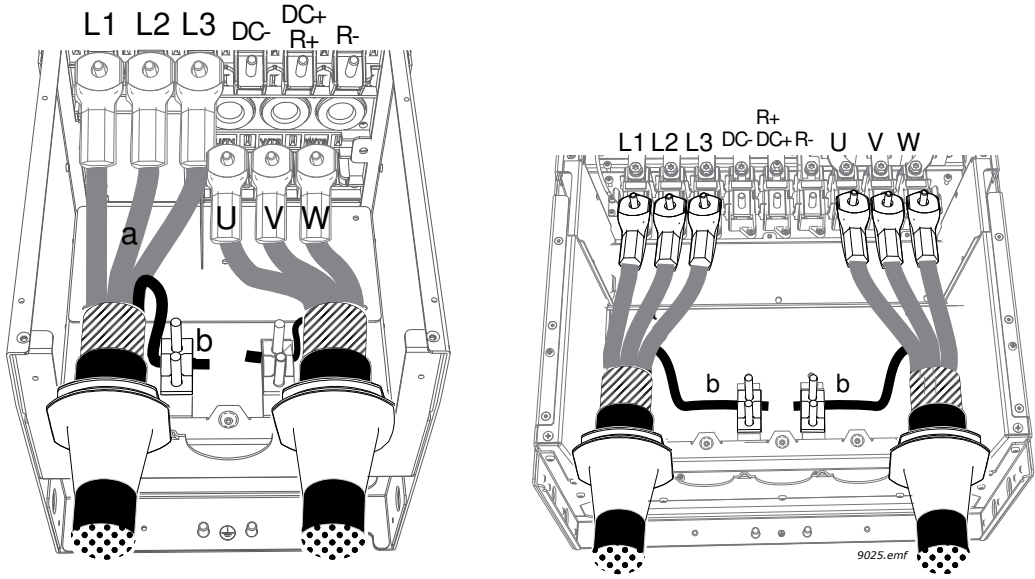
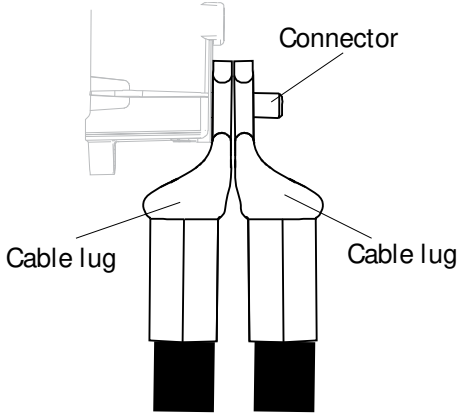

Figure 31: Connecting Power Cables; Left: FS8, Right: FS9.



9015.emf

Figure 32: Placing Two Cable Lugs on Top of Each Other.

Tightening Torques of Cable Terminals:

Table 18: Tightening Torques of Terminals.

Frame	Product Number	Maximum Tightening Torque Nm/lb-in.					
		Power and Motor Terminals		EMC Grounding Clamps		Grounding Terminals	
		Nm	lb-in.	Nm	lb-in.	Nm	lb-in.
FS8	BT300-050X2...	30	266	1.5	13.3	20	177
	BT300-060X2...						
	BT300-075X2...						
	BT300-100X4...						
	BT300-125X4...						
	BT300-150X4...						
	BT300-075X6...						
	BT300-100X6...						
	BT300-125X6...						
FS9	BT300-100X2...	40	354	1.5	13.3	20	177
	BT300-125X2...						
	BT300-200X4...						
	BT300-250X4...						
	BT300-150X6...						
	BT300-200X6...						

- Expose the shield of all three cables to make a 360-degree connection with the cable clamp.

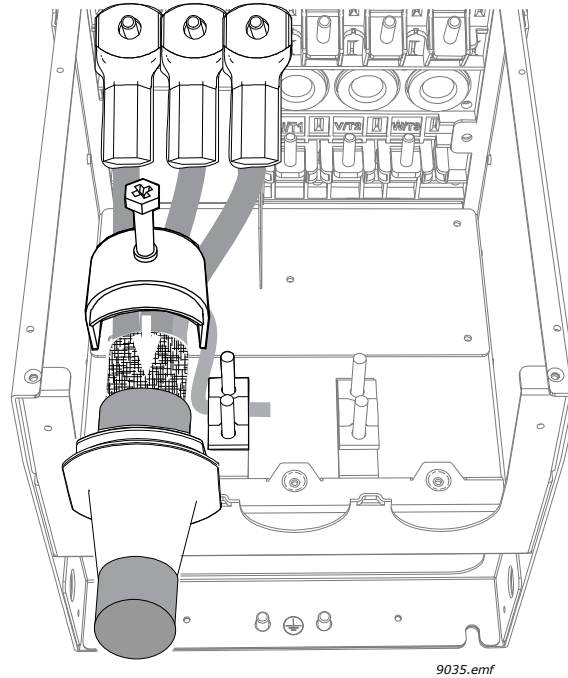

Figure 33: Exposing Cable Shields.

10. First, remount the EMC shield plate (see Figure 33 [→ 40]), and then remount the FS9 sealing plate (see Figure 32 [→ 40]).
11. Reattach the cable fitting plate and then the cable cover.

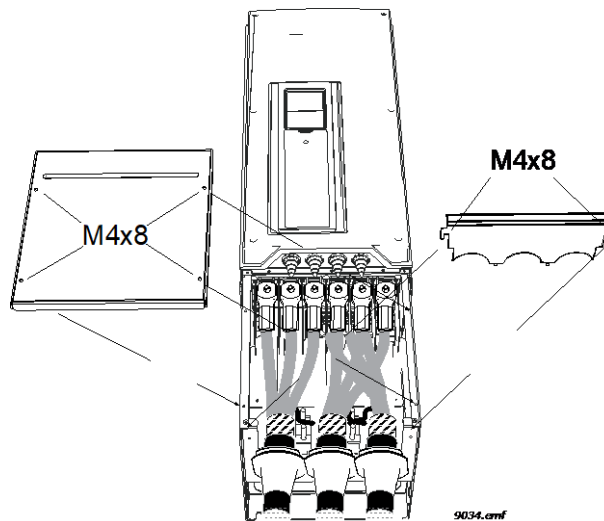

Figure 34: Reattaching Cable Fitting Plate and Cover.

12. **FS9 only:** Re-mount the main cover (unless you want to make the control connections first).

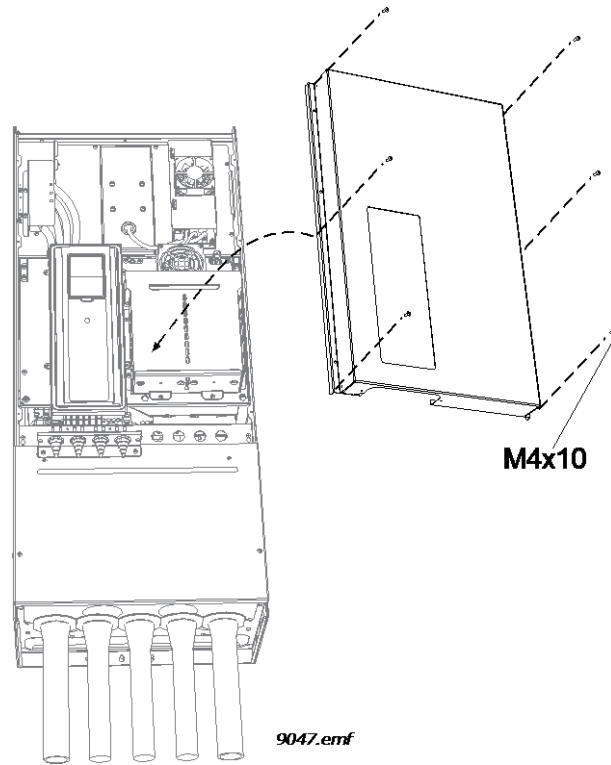



Figure 35: Re-mounting the Main Cover (FS9).

13. Check the connection of the grounding cable to the motor and the drive terminals marked with .

!	<p>NOTICE</p> <p>Two protective conductors are required according to standard EN 61800-5-1. For more information, see the <i>Grounding and ground fault protection</i> section [→ 10]. Connect the protective conductor using a cable shoe and an M8 screw (included in the <i>Accessories bag</i>) on either of the screw connectors as advised in the following figure.</p>
----------	---

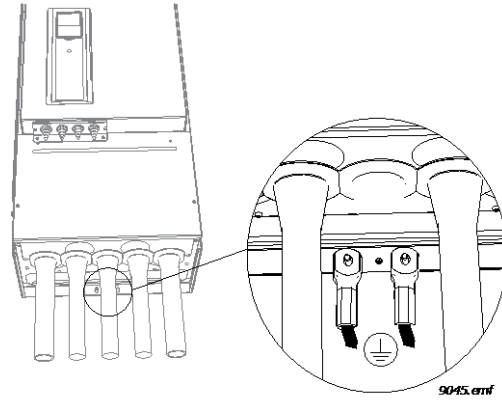

Figure 36: Connecting the Protective Conductor.

Installation in Corner-Grounded Network

Corner grounding is allowed for the drive types FS7 to FS9 with a rating from 72A to 310A at 380 to 480V supply and from 75A to 310A at 208 to 240V supply.

In these circumstances the EMC protection class must be changed to level C4 following the instructions in *Chapter 6, Installation in an IT System* section of this manual.

Corner grounding is not allowed for the drive types FS4 to FS6 with a rating from 3.4A to 61A at 380 to 480V supply and 3.7A to 62A with 208 to 240V supply.

Chapter 5 - Control Unit

The control unit of the AC drive consists of the control board and additional boards (option boards) connected to the slot connectors of the control board.

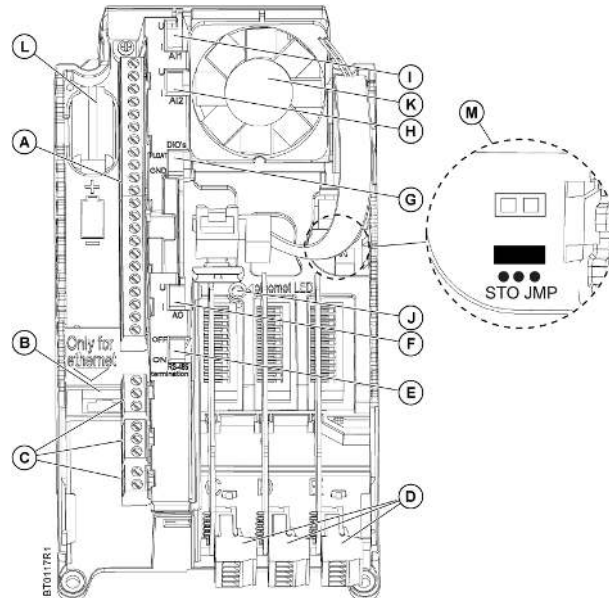

Figure 37: Location of Control Unit Components.

- A Control terminals for the standard I/O connections
- B Ethernet connection
- C Relay board terminals for 3 relay outputs or 2 relay outputs and a thermistor
- D Optional boards
- E DIP switch for RS485 bus termination
- F DIP switch for signal selection of Analog Output
- G DIP switch for isolation of the digital inputs from ground
- H DIP switch for signal selection of Analog Input 2
- I DIP switch for selection of Analog Input 1
- J Status indicator of the Ethernet connection.
- K Fan (only in IP54 of MR4 and MR5)
- L RTC battery
- M Default position of the Safe Torque Off (STO) jumper

When delivered from the factory, the control unit of the drive contains the standard controlling interface—the control terminals of the control board and the relay board—unless otherwise specifically ordered. On the next pages you will find the arrangement of the control I/O and the relay terminals, the general wiring diagram and the control signal descriptions.

The control board can be powered externally (+24 Vdc, 100 mA, $\pm 10\%$) by connecting the external power source to terminal #30; see the figure in the *Control Terminals and DIP Switches* section on page [→ 51]. This voltage is sufficient for parameter setting and for keeping the control unit active. Note however, that the

measurements of the main circuit (for example, DC-link voltage, unit temperature) are not available when line voltage is not connected.

Control Cable Sizing

The control cables shall be at least 0.5 mm² (30 AWG) screened multi-core cables, see the table in the *Power Cabling* section. The maximum terminal wire size is 2.5 mm² (14 AWG) for the relay and other terminals.

The following table outlines the tightening torques of the control and relay board terminals.

Table 19: Control Cable Tightening Torques.

Terminal Screw	Tightening Torque	
	Nm	lb-in.
All I/O and relay terminals (screw M3)	0.5	4.5

Control Terminals and DIP Switches

The basic control unit connections are presented in the following figure. The control board is equipped with 22 fixed control I/O terminals and the relay board with 8 or 9. The relay board is available in two different configurations.

The terminals of the *Basic I/O board* and the *Relay boards* are described below. For more information on the connections, see the following figure.

The terminals shown on shadowed background are assigned for signals with optional functions selectable with DIP switches. See more information in the *Selecting Terminal Functions and Isolating Digital Inputs from Ground with DIP Switches* section.

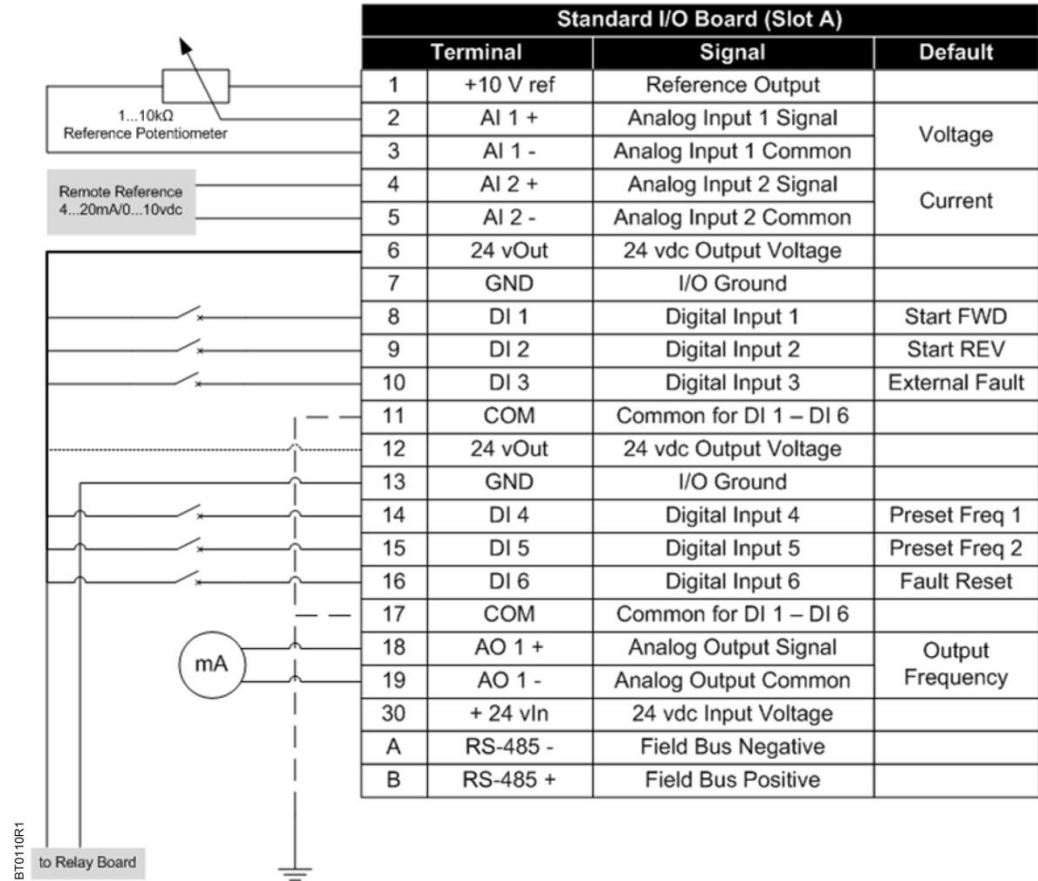

Figure 38: Control I/O Terminal Signals on Basic I/O Board and Connection Example.

*Digital inputs can be isolated from ground, see the *Selecting Terminal Functions and Isolating Digital Inputs from Ground with DIP Switches* section.

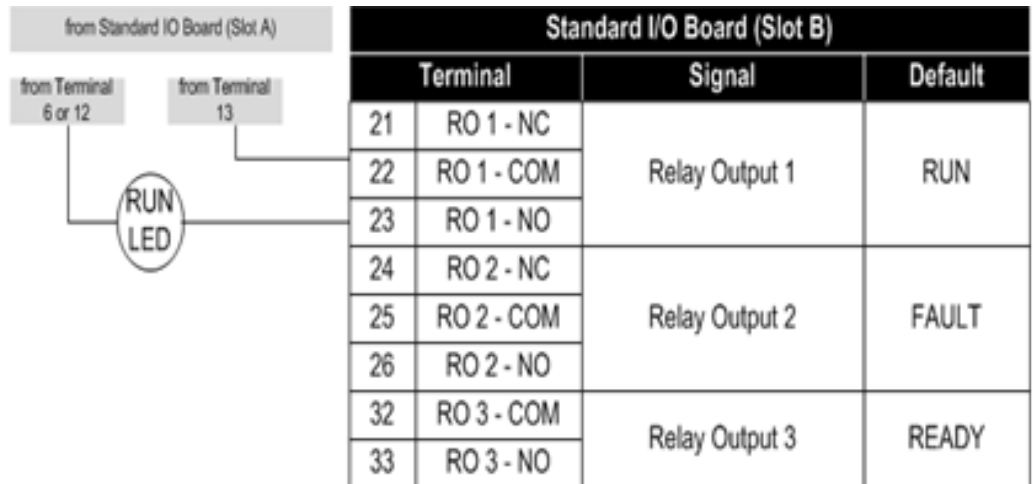

Figure 39: Slot B Terminal Connections.

Selecting Terminal Functions and Isolating Digital Inputs from Ground with DIP Switches

Current/Voltage Selection

The terminals in Figure 46 [→ 53] allow for three functional selections (current/voltage reference signal) each with *DIP switches*. The switches have two positions: left (current signal) and right (voltage signal). See the following figure for the switch locations and to make appropriate selections for your requirements.

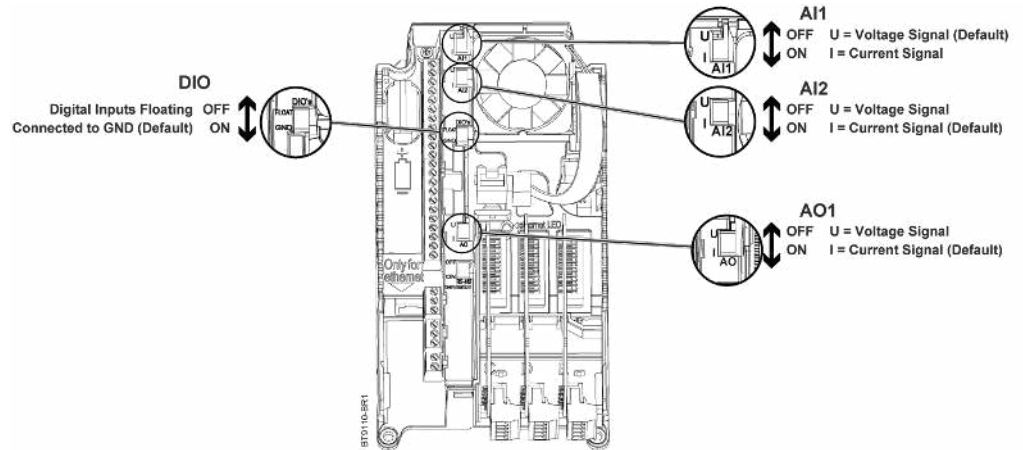

Figure 40: DIP Switches.

Bus Termination

If necessary, the bus termination can be set with the respective DIP switch. Locate the switch under the control cover of the drive and turn the switch for the RS485 bus termination resistor to position **ON**.

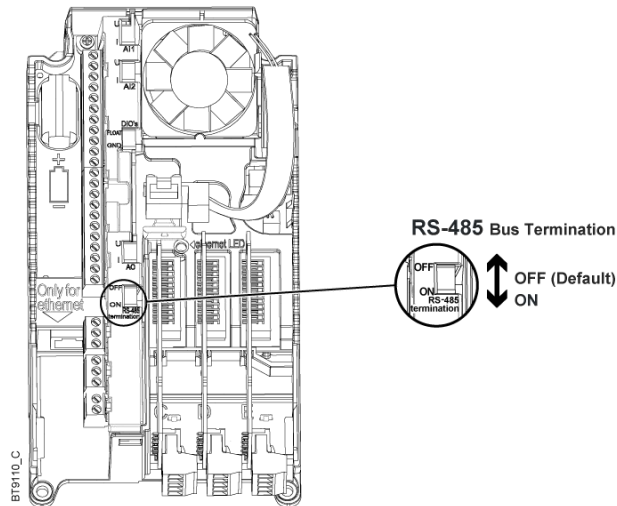

Figure 41: Bus Termination.

Isolating Digital Inputs from Ground

The digital inputs (terminals 8-10 and 14-16) on the standard I/O board can also be isolated from ground by setting the DIP switch on the control board to position **OFF**.

See Figure 46 [→ 53] to locate the switches and make appropriate selections for your requirements.

I/O Cabling and Fieldbus Connection

The AC drive can be connected to fieldbus either through RS485 or Ethernet. The connection for RS485 is on the basic I/O board (terminals A and B) and the connection for Ethernet is under the drive cover, left to the control keypad. See the following figure.

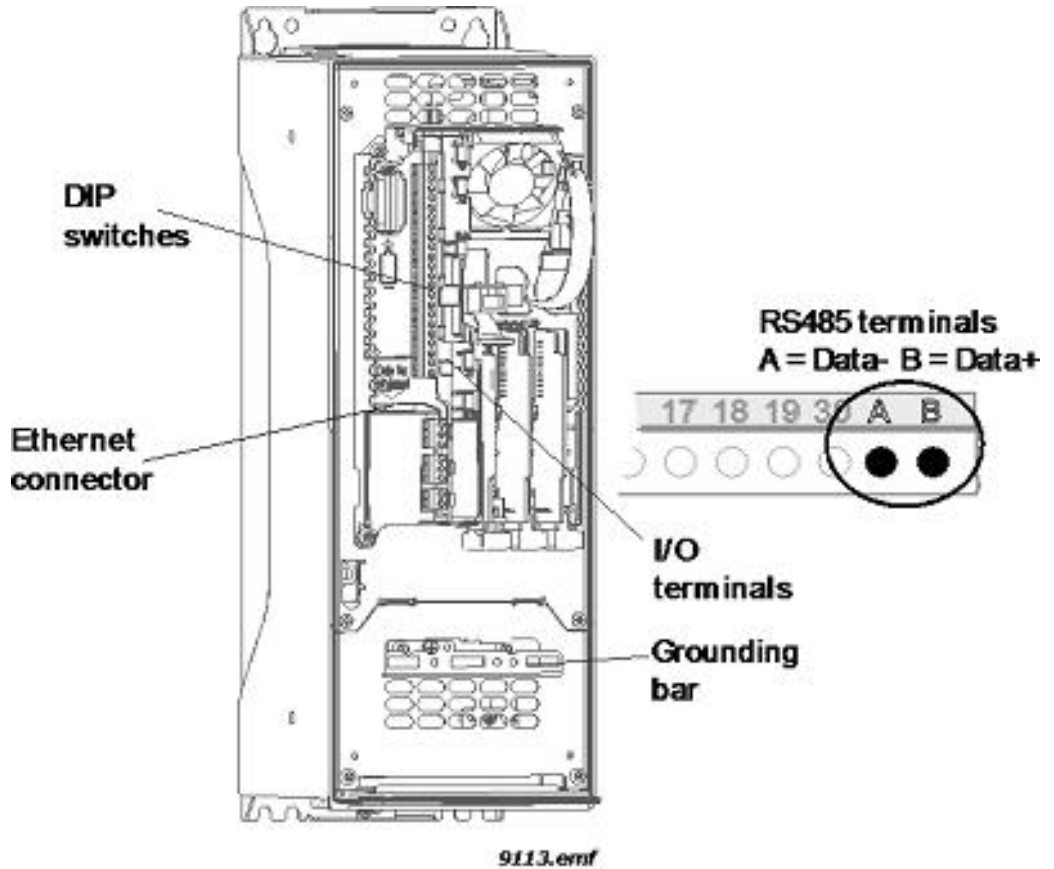

Figure 42: Ethernet and RS-485 Connections.

Prepare for Use with Ethernet

Ethernet Cable Data

Table 20: Ethernet Cable Specifications.

Connector	Shielded RJ-45 connector; NOTE: Maximum connector length is 1.57 in (40 mm).
Cable type	CAT5e STP
Cable length	Maximum 328 ft (100 m)



NOTE:

Ensure that the length of the connector does not exceed 1.57 in (40 mm).

1. Connect the Ethernet cable (see the specification table in this section) to its terminal and run the cable through the rubber grommets as other I/O cables.
2. **Do one of the following:**
 - **Protection class Type 1/IP21:** Cut free the opening on the drive cover for the Ethernet cable.
 - **Protection class Type 12/IP54:** Cut the rubber grommets open to slide the cables through. Should the grommets fold in while inserting the cable, just draw the cable back a bit to straighten the grommets up. Do not cut the grommet openings wider than what is necessary for the cables you are using.



NOTICE

To meet the requirements of the enclosure class Type 12/IP54, the connection between the grommet and the cable must be tight. Therefore, lead the first bit of the cable out of the grommet **straight** before letting it bend. If this is not possible, the tightness of the connection must be ensured with insulation tape or a cable tie.

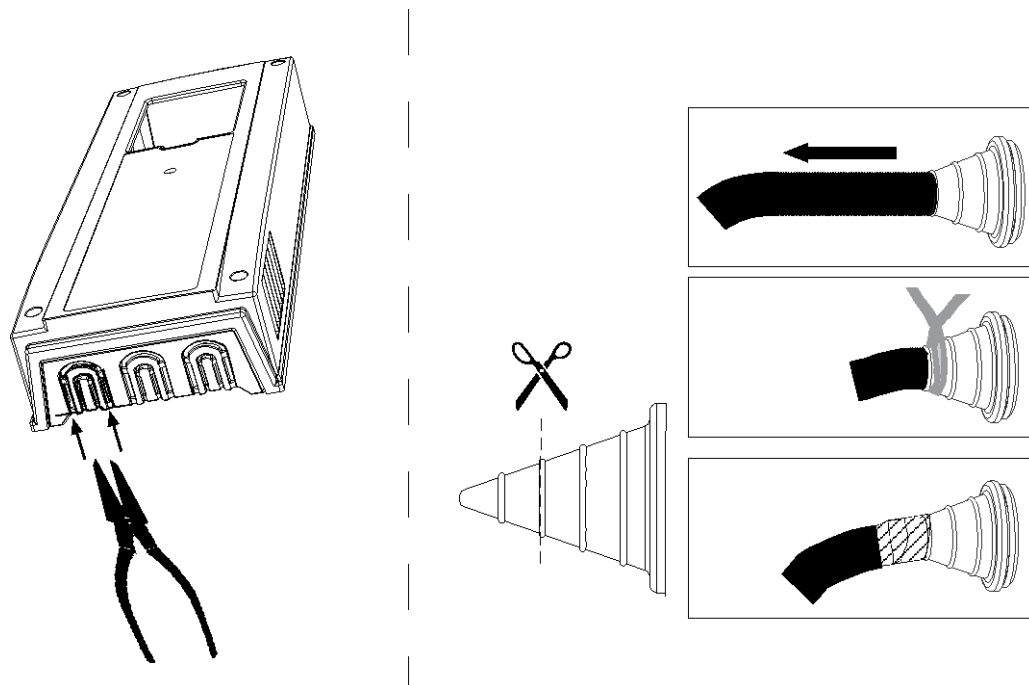

9068.emf

Figure 43: Leading the Cables, Left: IP21, Right: IP54.

3. Remount the drive cover.



NOTICE

When planning the cable runs, remember to keep the distance between the Ethernet cable and the motor cable at a **minimum of 11.8 in (30 cm)**.

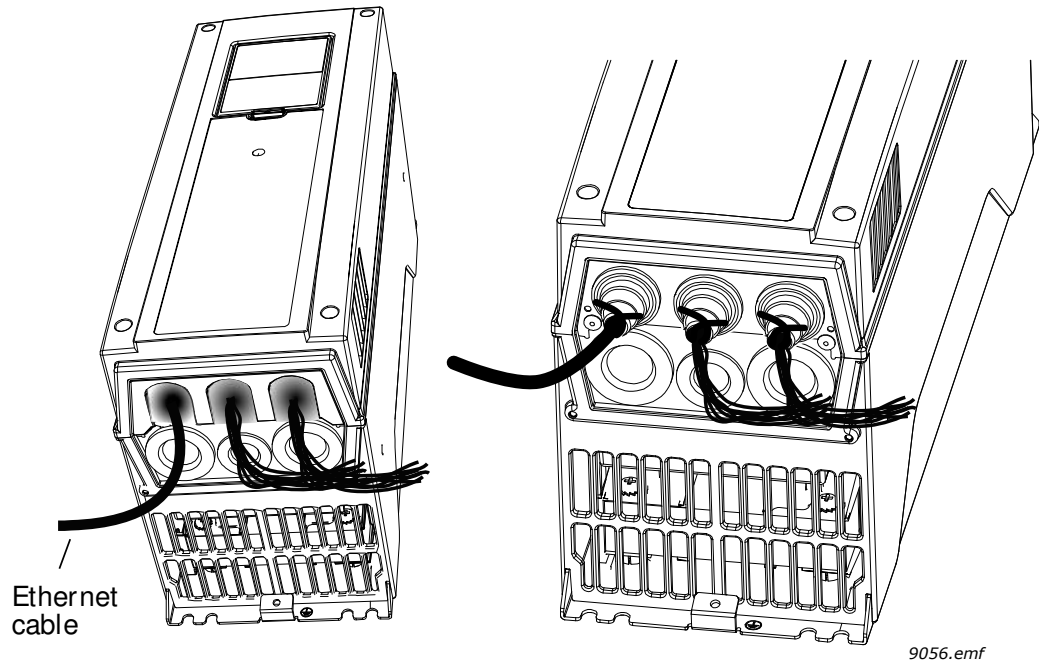

9056.emf

Figure 44: Distance between cables, Left: IP 21, Right: IP54.

For more detailed information, see the user's manual of the fieldbus you are using.

Prepare for use through RS-485

RS-485 Cable Data

Table 21: RS-485 Cable Specifications.

Connector	14 AWG (2.5 mm ²)
Cable type	Multi-Conductor - Low Capacitance Computer Cable for EIA RS-485 Applications 1-Pair 24 AWG, polyethylene insulation, STP (Shielded Twisted Pair), PVC jacket (Anixter #B9841 or similar)
Cable length	Depends on the used fieldbus. See respective bus manual.

1. Strip about 0.6 in (15 mm) of the RS-485 cable (see the specification table in this section) and cut off the gray cable shield. Do this for both bus cables.
2. Leave no more than 0.4 in (10 mm) of the cable outside the terminal block and strip the cables at about 0.2 in (5 mm) to fit in the terminals. See the following illustration.

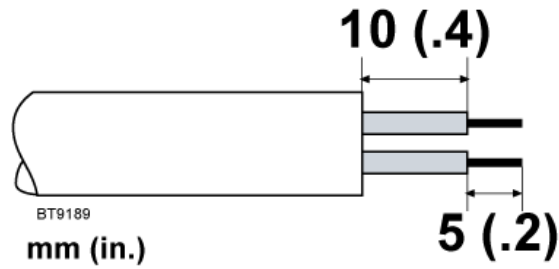
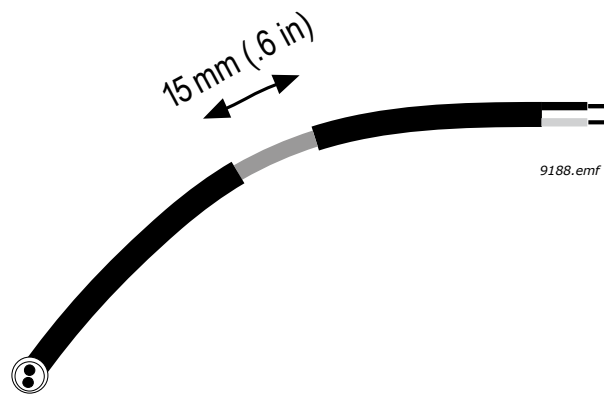

Figure 45: Stripping an RS-485 Cable.

3. Strip the cable at such a distance from the terminal that you can attach it to the frame with the grounding clamp. Strip the cable at a maximum length of 0.6 in (15 mm).

⇒ **Do not strip the aluminum cable shield!**



4. Connect the cable to its appropriate terminals on the Siemens BT300 HVAC Drive standard terminal block, terminals **A and B** (A = negative, B = positive). See the following figure.

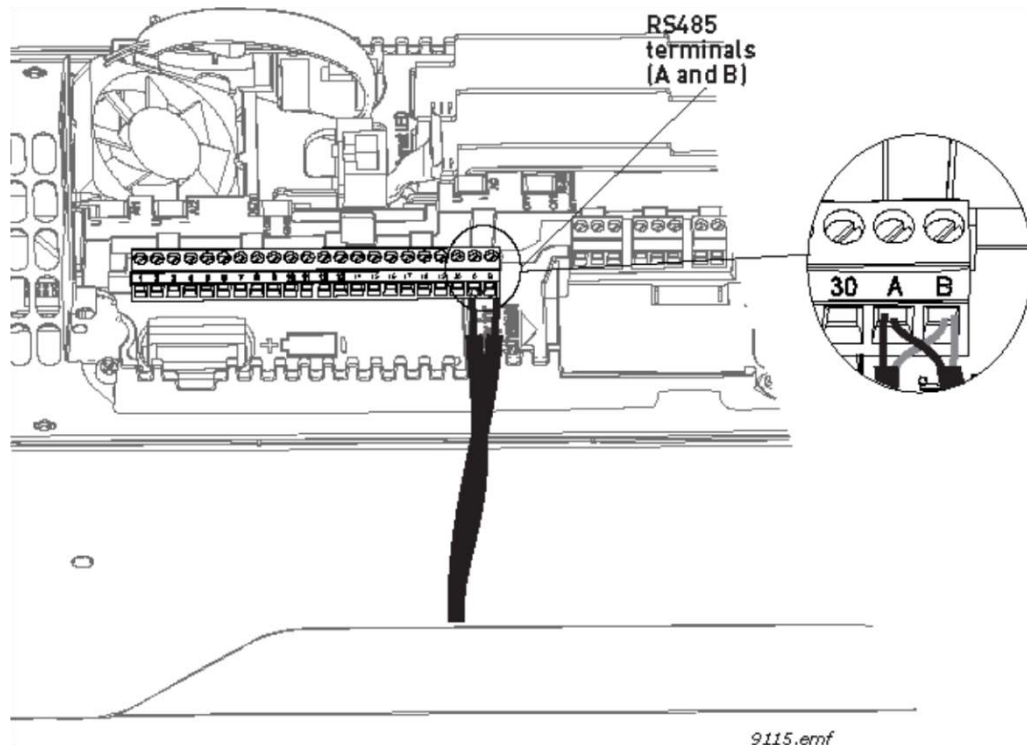

Figure 46: Connecting the RS-485 Cable.

5. Using the cable clamp included in the delivery of the drive, ground the shield of the RS-485 cable to the frame of the drive.

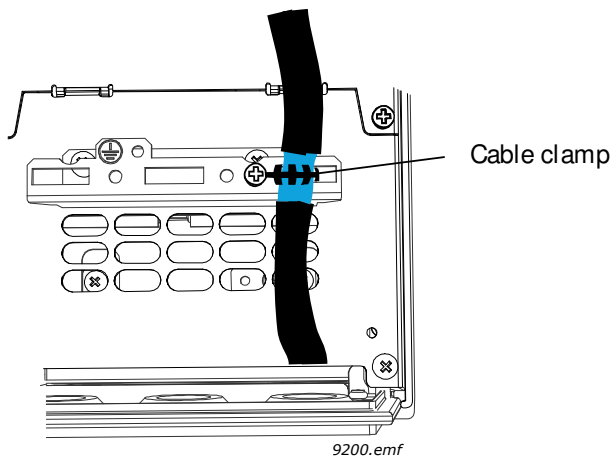

Figure 47: Grounding the RS-485 Cable Shield.

6. **If the Siemens BT300 HVAC Drive is the last device on the bus**, the bus termination must be set. Perform the following steps:
 - Locate the DIP switches to the right of the control keypad of the drive.
 - Set the switch for the RS-485 bus termination resistor to the **ON** position.
 - ⇒ Biasing is built in the termination resistor. See also Step 9 in this procedure.

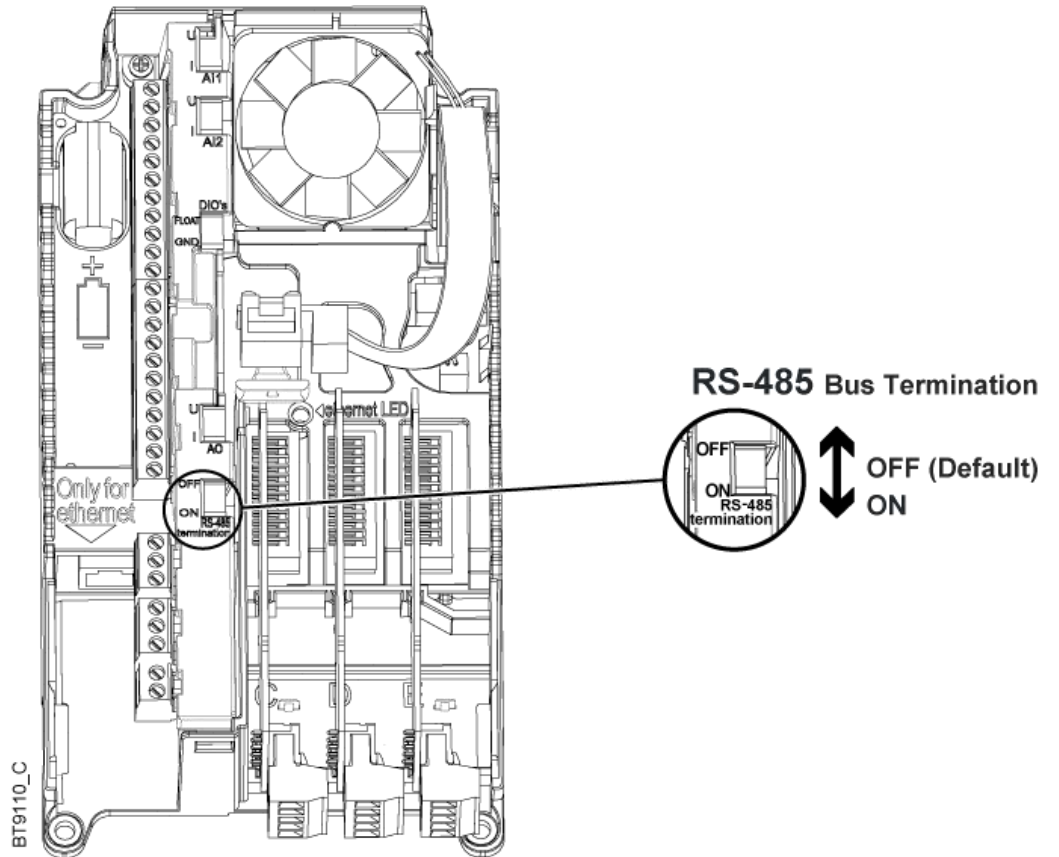

Figure 48: Bus Termination.

7. Unless already done for the other control cables, cut free the opening on the drive cover for the RS-485 cable (protection class Type 1/IP21).

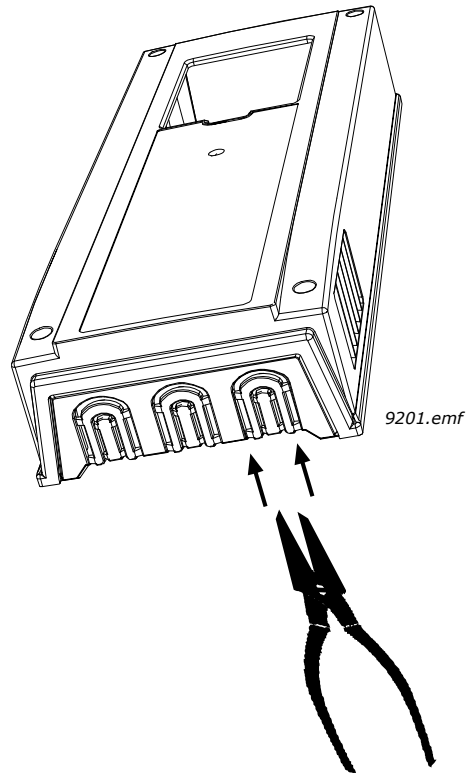

Figure 49: Cutting the Drive Cover Openings.

8. Reattach the drive cover and run the RS-485 cables as shown in the following figure.

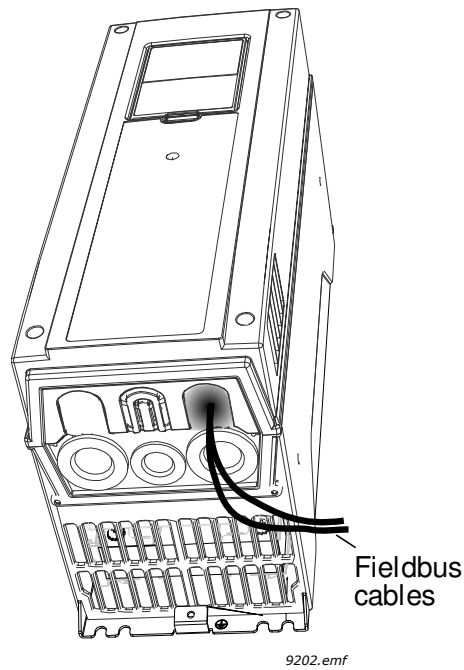

Figure 50: Reattaching the Drive Cover.

!	NOTICE
	When planning the cable runs, remember to keep the distance between the Ethernet cable and the motor cable at a minimum of 11.8 in (30 cm) .

9. The bus termination must be set for the first and the last device of the fieldbus cable. See the following illustration. Also see Step 6 in this procedure.
- ⇒ Siemens Industry, Inc. recommends that the first (terminated) device on the cable be the Master device.

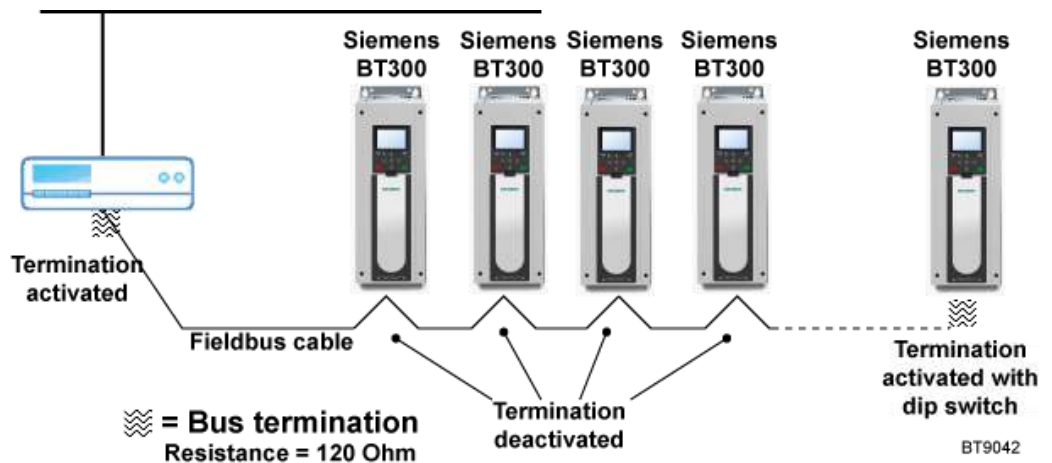

Figure 51: Fieldbus Cable.

Option Board Installation

!	NOTICE
	Do not add or replace option boards or fieldbus boards on an AC drive with the power switched ON. This may damage the boards.

The option boards are placed in the board slots on the drive.
The following table provides information about which option board can be placed in which board slot on the drive.

Table 22: Option Board Compatibilities for Board Slots.

Option Board Type	Board Description	Insertable in Slots
BT300-OPT-B1-V	I/O expansion board with six bidirectional digital signals (6x DI/DO, Programmable)	C, D, E
BT300-OPT-B2-V	I/O expansion board with two relay outputs and one thermistor (2x RO + Thermistor)	C, D, E
BT300-OPT-B4-V	I/O expansion board with one isolated analog input and two isolated analog outputs with a standard o(4) to 20 mA signal (1x AI, 2x AO Isolated)	C, D, E
BT300-OPT-B5-V	I/O expansion board with three relay outputs (3x RO)	C, D, E

Option Board Type	Board Description	Insertable in Slots
BT300-OPT-B9-V	I/O expansion board with one relay output and five 42 to 240 VAC digital inputs (1x RO, 5x DI [42 to 240 Vac])	C, D, E
BT300-OPT-BF-V	I/O expansion board with one analog output, one digital output, and one relay output (1x AO, 1x DO, 1x RO)	C, D, E
BT300-OPT-BH-V	I/O expansion board with three individual temperature measurement channels (NI100 Sensor Card)	C, D, E

For more information about the installation and operation of the option boards, see the *Siemens BT300 Option Boards User Manual* (DPD01158).

Battery Installation for Real Time Clock (RTC)

To enable the *Real Time Clock (RTC)* functions, a battery has been installed in the Siemens BT300 HVAC Drive.

Use a 1/2 AA battery with voltage of 3.6V and capacity of 1000 to 1200 mAh (for example, Panasonic BR-1/2 AA or Vitzrocell SB-AA02). The battery will last approximately ten years.

The place for the battery can be found in all frames left to the control keypad (see the figure in the *Control Unit* section on page [→ 50]).

Detailed information on the functions of the Real Time Clock (RTC) can be found in the *Siemens BT300 HVAC Drive Operator's Manual* (DPD01809).

Galvanic Isolation Barriers

The control connections are isolated from line voltage potential and the GND terminals are permanently connected to ground. See the following figure.

The digital inputs are galvanically isolated from the I/O ground. The relay outputs are additionally double-isolated from each other at 300 Vac (EN-50178).

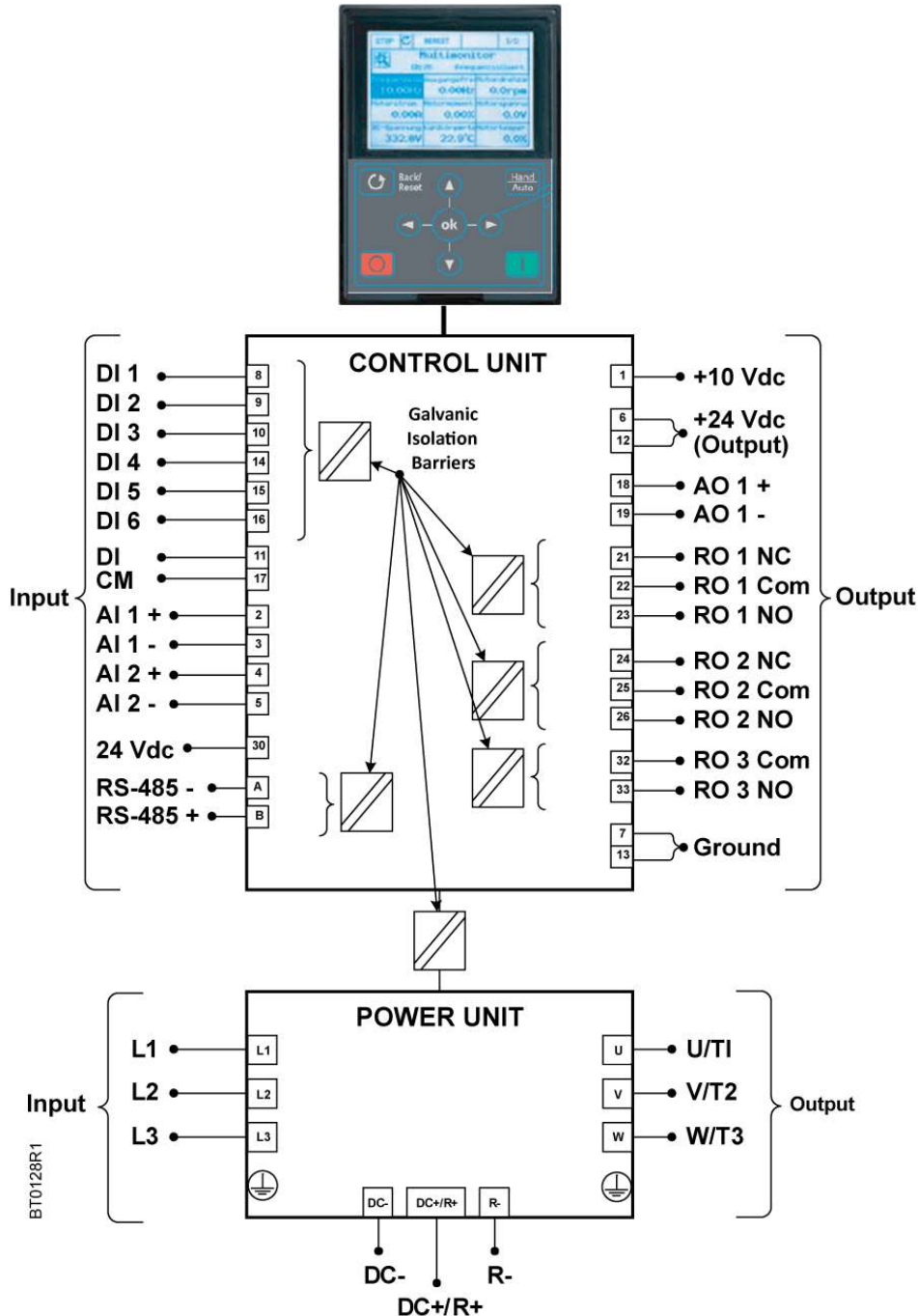







Figure 52: Galvanic Isolation Barriers.

Chapter 6 - Commissioning

Before commissioning, note the following directions and warnings:

	<p>⚠ DANGER</p> <p>Internal components and circuit boards of the BT300 Drive (except for the galvanically isolated I/O terminals) are live when it is connected to line voltage. Coming into contact with this voltage is extremely dangerous and may cause death or severe injury.</p> <p>Les composants internes et les cartes de circuits du variateur BT300 (sauf les bornes E/S isolées galvaniquement) sont sous tension lorsque celui-ci est raccordé à la tension de ligne. Tout contact avec cette tension est extrêmement dangereux et peut provoquer des blessures graves, voire mortelles.</p>
	<p>⚠ DANGER</p> <p>The motor terminals U, V, W and the R+ and R- terminals are live when the BT300 Drive is connected to line voltage, even when the motor is not running. Les bornes U, V W du moteur, et les terminaux R+ et R- sont sous tension lorsque le variateur BT300 est connecté à la tensions de ligne, même si le moteur n'est pas en marche.</p>
	<p>⚠ DANGER</p> <p>The control I/O-terminals are isolated from the primary input voltage. However, the relay outputs and other I/O-terminals may have a dangerous control voltage present even when the BT300 Drive is disconnected from line voltage. Les bornes d'E/S de commande sont isolés de la tension de ligne. Cependant, les sorties relais et les autres bornes d'E/S peuvent être alimentées en tension de commande dangereuse, même lorsque le variateur Siemens BT300 est hors tension.</p>
	<p>⚠ DANGER</p> <p>Do not make any connections to or from the AC drive when it is connected to the line voltage.</p> <p>Ne pas effectuer de conexions ver le ou du variateur lorsque celui-ci est raccordé à la tension de ligne.</p>

	<p>⚠ DANGER</p>
<p>Always ensure absence of voltage before starting any electrical work! After disconnecting the drive from line voltage, wait until the indicators on the keypad go out (if no keypad is attached see the indicators on the cover). Wait 5 more minutes before doing any work on the connections of the BT300 Drive. Do not open the cover before this time has expired. After expiration of this time, use a measuring equipment to absolutely ensure that no voltage is present. Veillez vous assurer en toute circonstance que la tension d'alimentation est coupée avant tout raccordement électrique. Après avoir débrancher le variateur de la tension de ligne, vous devez attendre l'extinction des voyants sur le panneau opérateur (si aucun panneau opérateur n'est raccordé, voir les voyants sur le capot). Attendez cinq minutes supplémentaires avant de commencer tout travail sur les bornes du variateur Siemens BT300. Ne pas ouvrir le capot avant la fin de cette période d'attente. À l'expiration de cette période, utilisez un instrument de mesure pour vous assurer qu'aucune tension n'est présente.</p>	

	<p>⚠ DANGER</p>
<p>Before connecting the drive to the primary input voltage make sure that the front and cable covers of the BT300 Drive are closed. Avant de brancher le variateur à la tension de ligne, assurez-vous que les capots avant et de câblage du variateur Siemens BT300 sont fermés.</p>	

<p>!</p>	<p>NOTICE</p>
<p>Corner grounding is allowed for the drive types with ratings from 72 A to 310 A at 380V through 480V supply and from 75A to 310A at 208V through 240V supply. Remember to change the EMC level by removing the jumpers. See Chapter 6.3 [→ 67].</p>	



NOTE:

R+ and **R-** terminals are not used in the Siemens BT300 Drive and external components must not be connected to them.

Commissioning the Drive

Carefully read the safety instructions in Chapter 1 and above information and follow them.





After the installation:

- Before connecting the drive to mains: Check **mounting and condition** of all fuses and other protective devices.
- Check that both the drive and the motor are **grounded**.
- Check that the mains and motor cables **comply with the requirements** given in Chapter 4.1.1.

- Check that the control cables are **located as far as possible** from the power cables, see Chapter 4.2.
- Check that the **shields** of the shielded cables are **connected to protective ground** marked with ⚡.
- Check the **tightening torques** of all terminals
- Check that the **wires do not touch** the electrical components of the drive.
- Check that the common inputs of digital input groups are connected to +24V or ground of the I/O terminal or the external supply.
- Check the **quality and quantity** of cooling air (Chapter 3.2 and Table 13).
- Check the inside of the drive for **condensation**.
- **Check that all Start/Stop switches connected to the I/O terminals are in Stop-position.**
- Run the Startup Wizard (see the *Siemens BT300 HVAC Drive Operator's Manual (DPD01809)*).

Running the Motor

Motor Run Check List

	<p>⚠ WARNING</p> <p>Before starting the motor, check that the motor is mounted properly and ensure that the machine connected to the motor allows the motor to be started.</p> <p>Avant de démarrer le moteur, vérifiez que le moteur est correctement installé, et assurez-vous que le machine connecté au moteur permet à celui-ci d'être démarré.</p>
	<p>⚠ WARNING</p> <p>Set the maximum motor speed (frequency) according to the motor and the machine connected to it.</p> <p>Régler la vitesse maximum du moteur (fréquence) en fonction du moteur et de la machine à laquelle il est connecté.</p>
	<p>⚠ WARNING</p> <p>Before reversing the motor ensure that this can be done safely.</p> <p>Avant d'inverser le moteur, vous assurer que cela peut être effectué en toute sécurité.</p>
	<p>⚠ WARNING</p> <p>Ensure that the power correction capacitors are not connected to the motor cable.</p> <p>Vous assurer que les condensateurs d'amélioration du facteur de puissance ne sont pas connectés au câble du moteur.</p>



⚠ WARNING

Ensure that the motor terminals are **not** connected to line voltage.
Vous assurer que les bornes du moteur ne sont pas connectés à la tension de ligne.

Cable and Motor Insulation Checks

1. Motor cable insulation checks
Disconnect the motor cable from terminals U, V and W of the drive and from the motor. Measure the insulation resistance of the motor cable between each phase conductor, as well as between each phase conductor and the protective ground conductor. The insulation resistance must be >1 MOhm at ambient temperature of 20° C (68° F).
2. Mains cable insulation checks
Disconnect the mains cable from terminals L1, L2 and L3 of the AC drive and from the mains. Measure the insulation resistance of the mains cable between each phase conductor, as well as between each phase conductor and the protective ground conductor. The insulation resistance must be >1MOhm at ambient temperature of 20° C (68° F).
3. Motor insulation checks
Disconnect the motor cable from the motor and open the bridging connections in the motor connection box. Measure the insulation resistance of each motor winding. The measurement voltage must equal at least the motor nominal voltage, but not exceed 1000V. The insulation resistance must be >1 MOhm at ambient temperature of 20° C (68° F). Always follow the instructions of the motor manufacturer.

Installation in an IT System

If your supply network is an IT (impedance-grounded) system, but your drive is EMC-protected according to class C2, you must modify the EMC protection of the drive to EMC-level C4. This is done by removing the built-in EMC jumpers, which is outlined in the following procedure.



⚠ WARNING

Do not perform any modifications on the drive when it is connected to line voltage.
N'effectuez aucune modification sur le le variateur lorsqu'il est connecté à la tension de ligne.

Frames FS4 to FS6

1. Remove the main cover of the drive (see page [→ 33]) and locate the jumpers connecting the built-in RFI-filters to ground. See the following figures.

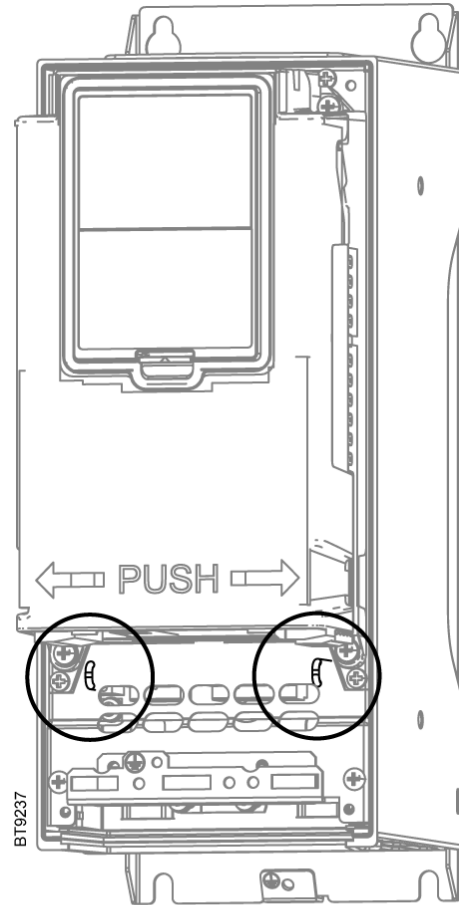

FS4

Figure 53: Location of the EMC-jumpers in Frame FS4.

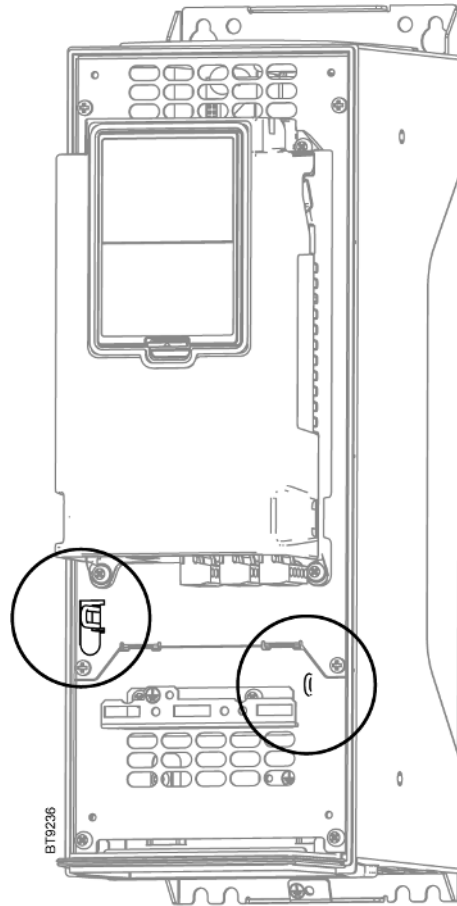

FS5

Figure 54: Location of the EMC-jumpers in Frame FS5.

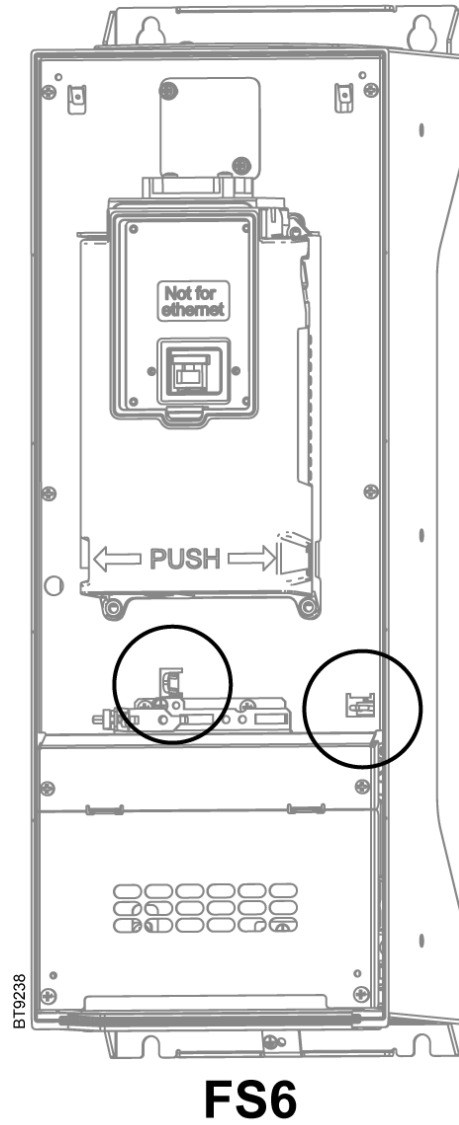
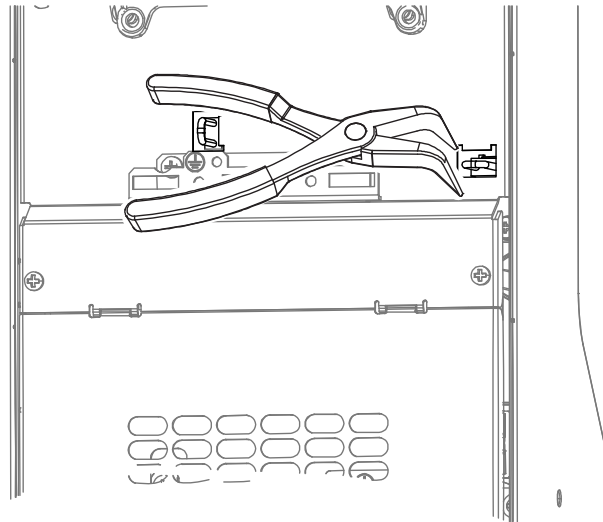
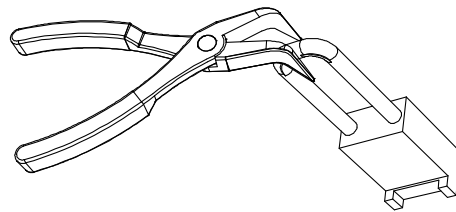

Figure 55: Location of the EMC-jumpers in Frame FS6.

2. Disconnect the RFI-filters from ground by **removing** the EMC-jumpers using long-nose pliers or similar. See the following figures.



9239.emf



9060.emf

Figure 56: Removing the Jumper, FS6 as Example.

Frames FS7 and FS8

Use the procedure in this section to modify the EMC protection of the drive of frames FS7 and FS8 to EMC-level C4.

1. Remove the main cover of the drive and locate the jumper. **FS8 only: Push down** the grounding arm. See the following figure.

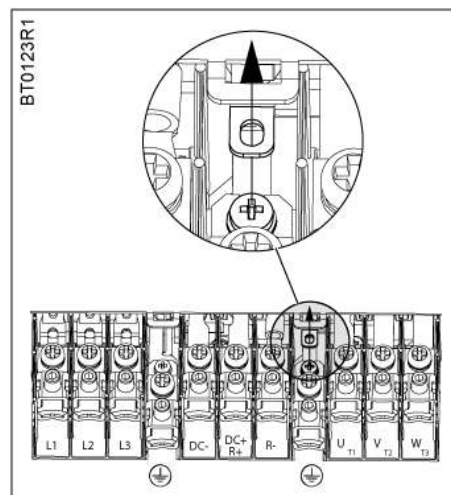

Figure 57: Grounding Arm, FS8.

2. **FS7 and FS8:** Locate the EMC box under the cover. Remove the screws of the box cover to expose the EMC-jumper. Detach the jumper and re-mount the box cover.

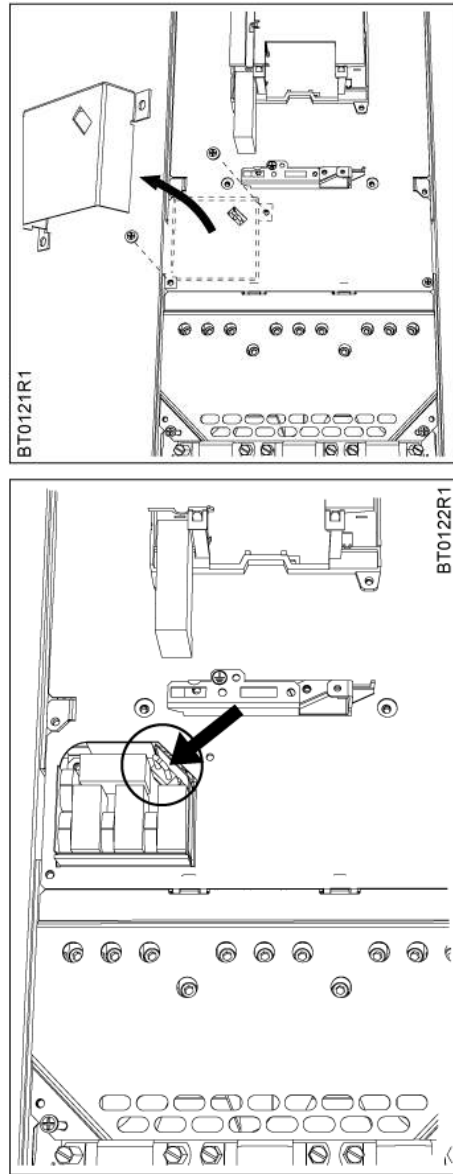

Figure 58: Detaching the EMC Jumper, FS7 and FS8.

3. **Additionally for FS7**, locate the DC grounding bus-bar between connectors **R-** and **U** and detach the bus-bar from the frame by removing the M4 screw.

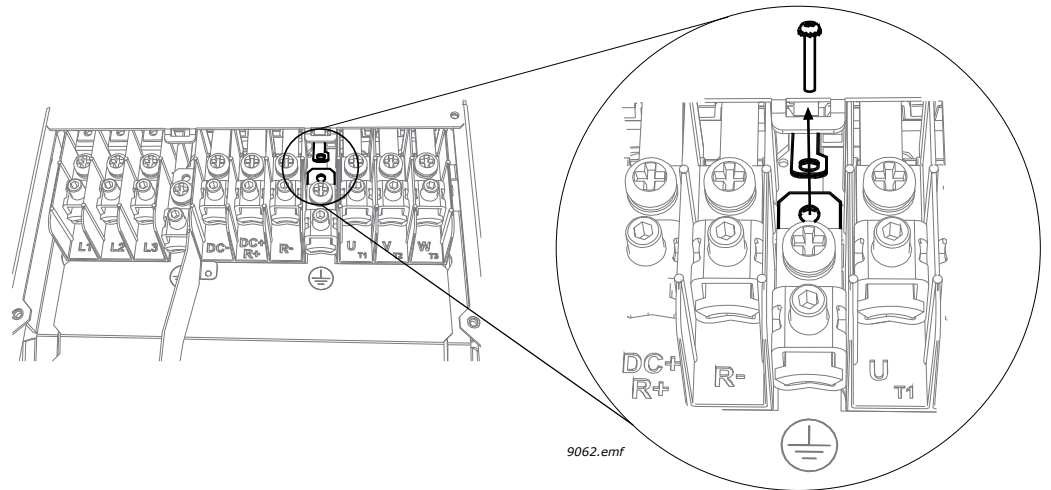

Figure 59: FS7: Detaching the DC Grounding Bus-Bar from the Frame.

Frame FS9

Use the procedure in this section to modify the EMC protection of the drive of frame FS9 to EMC-level C4.

1. Find the connector in the accessories bag. Remove the main cover of the drive and locate the place for the connector next to the fan. Push the connector in its place. See the following figure.

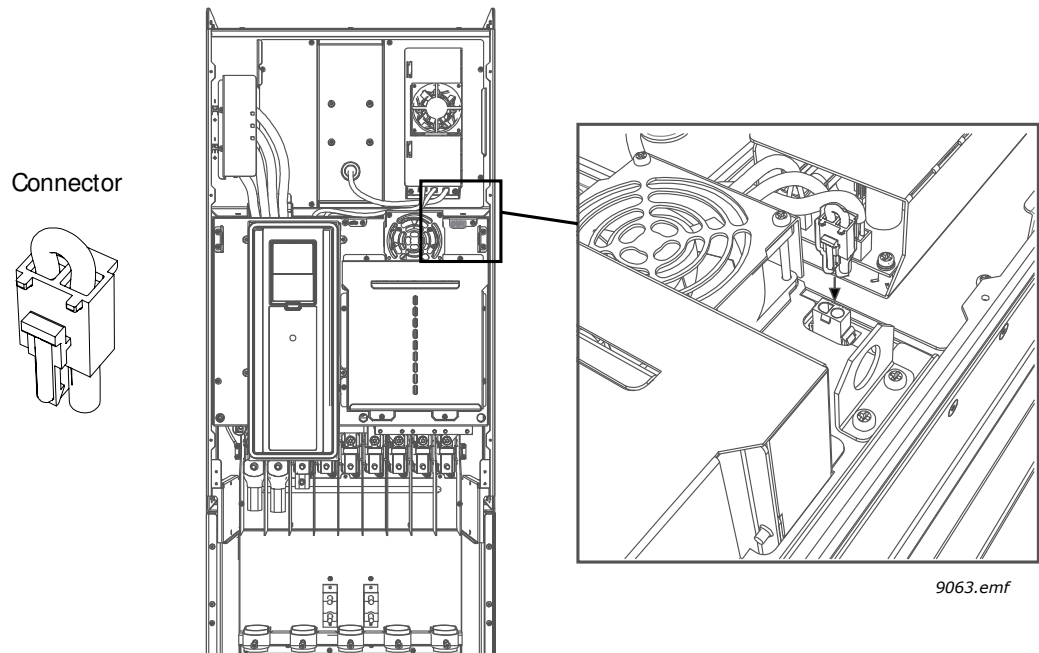
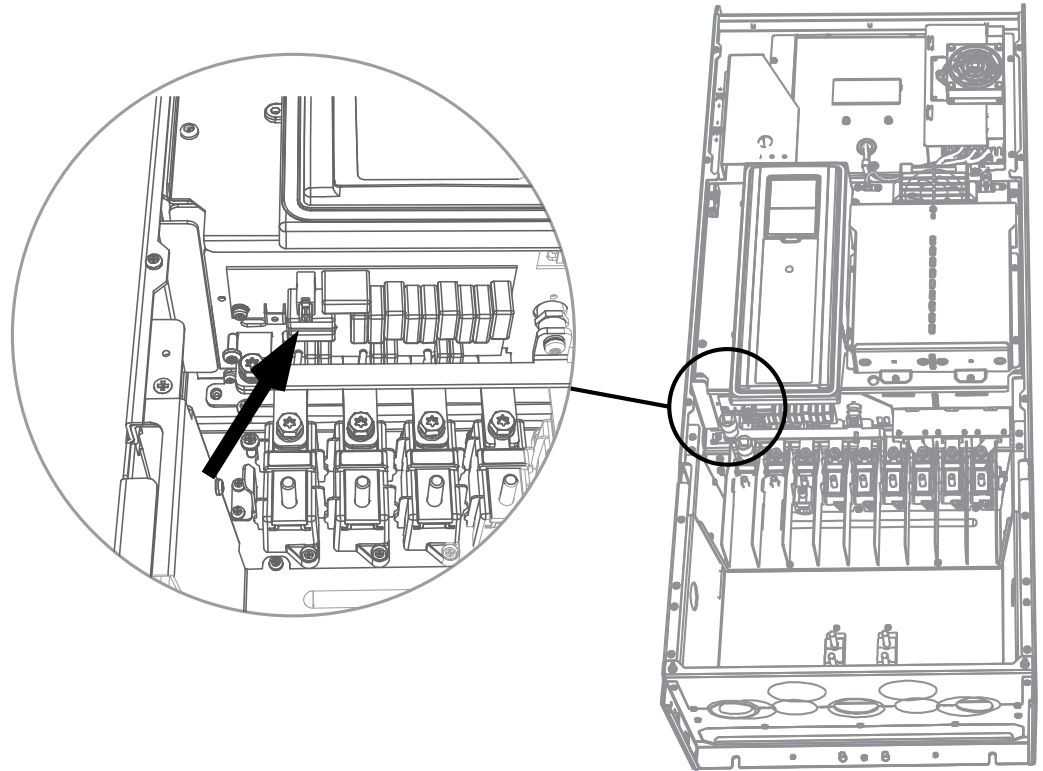

Figure 60: Placing the Connector.

2. Remove the extension box cover, the touch shield, and the I/O plate with I/O grommet plate. Locate the EMC jumper on the EMC board (see magnification in the following figure) and remove it.



9067.emf

Figure 61: Removing the EMC Jumper.

!	NOTICE
	Before connecting the drive to line voltage, ensure that the EMC protection class settings of the drive are appropriately made.

Maintenance

Regular maintenance is recommended to ensure trouble-free operation and a long lifetime of the drive. Siemens Industry, Inc. recommends following the table below for maintenance intervals.

!	NOTICE
	See the service manual for information on cleaning tools.



NOTE:

Because of capacitor type (thin film capacitors), reforming of capacitors is not necessary.

Maintenance Interval	Maintenance Action
Regularly and according to general maintenance interval	<ul style="list-style-type: none"> • Check tightening torques of terminals. • Check filters.
6 to 24 months (depending on environment)	<ul style="list-style-type: none"> • Check input and output terminals and control I/O terminals. • Check operation of cooling fan. • Check for corrosion on terminals, bus-bars and other surfaces. • Check door filters in cabinet installations.
24 months	<ul style="list-style-type: none"> • Clean heat sink and cooling tunnel.
3 to 6 years	<ul style="list-style-type: none"> • Change internal Type 12/IP54 fan.
6 to 10 years	<ul style="list-style-type: none"> • Change main fan.

Chapter 7 - Technical Data

Drive Power Ratings

HP	kW	Voltage											
		208-240	380-500	525-600	208-240	380-500	525-600	208-240	380-500	525-600	208-240	380-500	525-600
		Frame Size			Input Current			Output Current			10% OL Current		
1	0.75	4	4	5	4.2			4.8			5.3		
1.5	1.1				6.0	3.4		6.7	3.4		7.4	3.7	
2	1.5				7.2	4.6		8.0	4.8		8.8	5.3	
3	2.2	4	5	5	9.7	5.4	2.7	11.0	5.6	3.9	12.1	6.2	4.3
5	4				16.1	9.3	3.9	18.0	9.6	6.1	19.8	10.6	6.7
7.5	5.5	5	5	5	21.7	11.3	6.1	24.2	12.0	9.0	26.6	13.2	9.9
10	7.5	27.7			15.4	9.0	31.0	16.0	11.0	34.1	17.6	12.1	
15	11	6	5	6	43.8	21.3	13.5	48.0	23.0	18.0	52.8	25.3	19.8
20	15				57.0	28.4	18.0	62.0	31.0	22.0	68.2	34.1	24.2
25	18.5	7	6	6	69.0	36.7	22.0	75.0	38.0	27.0	82.5	41.8	29.7
30	22				82.1	43.6	27.0	88.0	46.0	34.0	96.8	50.6	37.4
40	30	8	7	7	99.0	58.2	34.0	105.0	61.0	41.0	115.5	67.1	45.1
50	37				135.1	67.5	41.0	143.0	72.0	52.0	157.3	79.2	57.2
60	45	8	7	7	162.0	85.3	52.0	170.0	87.0	62.0	187.0	95.7	68.2
75*	55				200.0	100.6	62.0	208.0	105.0	80.0	228.8	115.5	88.0
100*	75	9	8	8	253.0	139.4	80.0	261.0	140.0	100.0	287.1	154.0	110.0
125*	90				301.0	166.5	100.0	310.0	170.0	125.0	341.0	187.0	137.5
150	110	9	8	9	199.6	125.0		205.0	144.0		225.5	158.4	
200	132				258.0	170.0		261.0	208.0		287.1	228.8	
250	160	9	8	9	303.0			310.0			341.0		

* For use with 230 Vac and above.

Figure 62: Drive Power Ratings.



NOTE:

The rated currents in given ambient temperatures are achieved only when the switching frequency is equal to or less than the factory default. See the Table *Siemens BT300 Technical Data* in this chapter.

Definitions of Overload

Drive overload

Following continuous operation at rated output current I_L , the drive is fed with $110\% * I_L$ for 1 minute, followed by a period of I_L .

Example

If the duty cycle requires 110% rated current I_L for 1 minute in every 10 minutes, the remaining 9 minutes must be at or below the rated current.

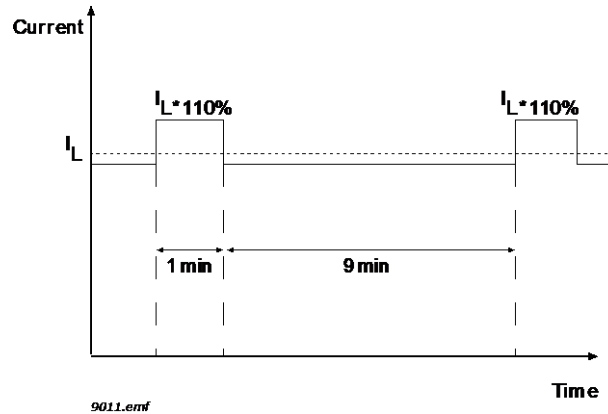

Figure 63: Drive Overload.

Technical Data

Table 23: Drive Specifications.

Specification	Description
Input Voltages and Power Ranges (3-phase)	208 to 240 Vac (-10% to +10%): 1 hp to 125 hp (0.75 kW to 90 kW) 380 to 500 Vac (-10% to +10%): 1.5 hp to 250 hp (1.1 kW to 160 kW) 525 to 600 Vac (-10% to +10%): 3 hp to 200 hp (2.2 kW to 132 kW)
Input Frequency	45 to 66 Hz (50 to 60 Hz; -5% to +10%)
Output Voltage	0 to Input voltage
Output Frequency	0 to 320 Hz
Output Frequency Resolution	0.01 Hz
Efficiency	>97.5%
PWM (switching) frequency	FS4 to FS6 - 1.5 to 10 kHz Default FS4: 6 kHz; FS5: 4 kHz; FS6 = 4 kHz FS7 to FS9 - 1.5 to 6 kHz Default FS7: 4 kHz; FS8: 3 kHz; FS9: 2kHz Adjustable in .1 kHz increments Automatic switching frequency derating in case of overheating
Short circuit withstand rating	100,000 AIC
Frequency Reference Analog Input Keypad	Resolution 0.01 to 0.1% (10 bit), accuracy $\pm 1\%$ Resolution 0.01 Hz
Field weakening point	8 to 320 Hz
Acceleration time	0.1 to 3000.0 seconds
Deceleration time	0.1 to 3000.0 seconds
Ambient Operating Temperature	14° F (-10° C) (no frost) to 104° F (40° C) up to 122° F (50° C) with derating
Relative Humidity	0 to 95% rh, non-condensing, non-corrosive
Air quality: Chemical vapors Mechanical particles	IEC 60068-2-60 (H ₂ S [hydrogen sulfide] and SO ₂ [sulfur dioxide]). IEC 60721-3-3, unit in operation, class 3C2 IEC 60721-3-3, unit in operation, class 3S3.

Specification	Description
Altitude	100% load capacity (no-derating) up to 3,280 ft (1,000 m) -1% derating for each 328 ft (100 m) above 3,280 ft (1,000 m) Maximum altitude: 208 to 240 Vac: 13,123 ft (4,000 m) 380 to 500 Vac: 13,123 ft (4,000 m) 525 to 600 Vac: 6,562 ft (2,000 m) Voltage for relay outputs: 240 Vac: ≤ 9,842 ft (3,000 m) 120 Vac: ≤ 13,123 ft (4,000 m) Corner-grounding (380-500 Vac systems only): ≤ 6,562 ft (2,000 m)
Fixed frequencies	7 programmable
Skip (prohibited) frequency band	3 programmable
Vibration	EN61800-5-1 EN60068-2-6
Seismic	2012 International Building Code (IBC), OSHPD
Shock	EN61800-5-1 EN60068-2-27
Enclosure Class	UL Type 1/IP 21 standard in entire HP/kW range. UL Type 12/IP 54 options
EMC Immunity	Fulfills IEC 61800-3 (2004), first and second environment
EMC Emissions	EN61800-3 (2004) Category C2 Can be field modified for IT networks for C3 or C4 ratings.
Embedded Protocols	RS-485: APOGEE P1, BACnet MS/TP (BTL), Modbus RTU, Metasys N2 Ethernet: BACnet IP (BTL), Modbus TCP
Heatsink cooling fan noise level in dB (low speed/high speed)	FS4: 45/56 FS5: 57/65 FS6: 63/72 FS7: 43/73 FS8: 58/73 FS9: 54/75
Heatsink cooling fan output	FS4: 49 CFM FS5: 88 CFM FS6: 219 CFM FS7: 159 CFM FS8: 426 CFM FS9: 560 CFM
Agency Approvals/Conformity	UL 508C; UL; cUL; CE; BTL ; RoHS compliant; EN61800-5-1 (2007).
Country of Origin (COO)	Finland
Control Method	Linear, parabolic and programmable V/f; and flux current control low-power mode
Control I/O: Analog Inputs Analog Outputs Digital Inputs Relay Outputs	2 - voltage (0/2 to 10 Vdc) or current (0/4 to 20 mA) Resolution 0.1%; Accuracy ±1% 1 - voltage (0/2 to 10 Vdc) or current (0/4 to 20 mA) <500 W; Resolution 0.1%; Accuracy ±1% 6 - programmable and isolated Positive or Negative logic; 5 kW; 0 to 5 Vdc = 0 ; 15 to 30 Vdc = 1 2 - Form C and 1 Normally Open 24 Vdc @ 8A; 250 Vac @ 8A; 125 Vac @ 0.4A

Specification	Description
Auxiliary input	24 Vdc \pm 10%, 250 mA
Auxiliary output	10 Vdc \pm 3%, 10 mA (short-circuit protected) 24 Vdc \pm 10%, 250 mA (short-circuit protected)
Embedded Protocols	RS-485: APOGEE P1, BACnet MS/TP, Modbus RTU, Metasys N2 Ethernet: BACnet IP, Modbus TCP
Over voltage trip limit	208 to 240 Vac: 456 Vdc 380 to 500 Vac: 911 Vdc 525 to 600 Vac: 1094 Vdc
Under voltage trip limit	Depends on supply voltage (0.8775* supply voltage): 208 Vac: 182.5 Vdc 240 Vac: 210.6 Vdc 380 Vac: 333.5 Vdc 480 Vac: 421.2 Vdc 575 Vac: 504.6 Vdc
Protection features	Under-voltage trip limit Over-voltage trip limit Ground fault protection Input (mains) supervision Motor phase supervision Over-current protection Unit over-temperature protection Motor overload protection Motor stall protection Motor underload protection Short-circuit protection of 10 Vdc and 24 Vdc reference voltages

Fieldbus Technical Data

	APOGEE P1	BACnet MS/TP	Modbus RTU	Metasys N2	BACnet IP	Modbus TCP
Interface	RS-485				100BaseT, 802.3	
Data Transfer Method	RS-485, half-duplex				Ethernet half/full duplex	
Transfer Cable	STP (Shielded Twisted Pair), type Belden 9841 or similar				CAT5e STP	
Connector	14 AWG (2.5 mm ²)				Shielded RJ45	
Baud Rate(s)	4800, 9600	9600, 19200, 38400, 76800	300, 600, 1200, 2400, 4800, 9600, 19200, 38400, 57600, 76800, 115200, 230400	9600	10/100 Mbits/s, auto-sensing	
Addresses	0 to 127	0 to 127	1 to 247	1 to 255	NA	

Control Board Technical Specifications

Table 24: Control Module Technical Specifications

Terminal	Signal/Description	Specification
Slot A		
1	+10 Vdc Reference Output	+3%; Maximum current 10 mA
2	Analog Input 1 Signal (+)	0-10 Vdc or 0-20 mA (selection with DIP switch) Resolution: 0.1%, Accuracy: $\pm 1\%$
3	Analog Input 1 Common (-)	
4	Analog Input 2 Signal (+)	0-10 Vdc or 0-20 mA (selection with DIP switch) Resolution: 0.1%, Accuracy: $\pm 1\%$
5	Analog Input 2 Common (-)	
6	24 Vdc Output Voltage	$\pm 10\%$; Maximum 250 mA
7	I/O Ground	
8	Digital Input 1	Positive or negative logic; 0 Vdc - 5 Vdc = 0 ; 15 Vdc - 30 Vdc = 1
9	Digital Input 2	
10	Digital Input 3	
11	Common for DI 1 - DI 6	
12	24 Vdc Output Voltage	$\pm 10\%$; Maximum 250 mA
13	I/O Ground	
14	Digital Input 4	Positive or negative logic; 0 Vdc - 5 Vdc = 0 ; 15 Vdc - 30 Vdc = 1
15	Digital Input 5	
16	Digital Input 6	
17	Common for DI 1 - DI 6	
18	Analog Output 1 Signal (+)	0-10 Vdc or 0-20 mA (selection with DIP switch) Resolution: 0.1%, Accuracy: $\pm 1\%$
19	Analog Output 1 Common (-)	
30	24 Vdc Input Voltage	$\pm 10\%$; Maximum 250 mA; Used for power backup of control unit.
A	RS-485 -	Fieldbus Negative
B	RS-485 +	Fieldbus Positive
Slot B		
21	Relay Output 1 Normally Closed	Switching capacity: 24 Vdc/8A; 250 Vac/8A; 125 Vdc/0.4A Minimum switch load: 5 Vdc/0 mA
22	Relay Output 1 Common	
23	Relay Output 1 Normally Open	
Slot B		
24	Relay Output 2 Normally Closed	Switching capacity: 24 Vdc/8A; 250 Vac/8A; 125 Vdc/0.4A Minimum switch load: 5 Vdc/0 mA
25	Relay Output 2 Common	
25	Relay Output 2 Normally Open	
Slot B		
32	Relay Output 2 Common	Switching capacity: 24 Vdc/8A; 250 Vac/8A; 125 Vdc/0.4A Minimum switch load: 5 Vdc/0 mA
33	Relay Output 2 Normally Open	



DPD01148J

Issued by
Siemens Industry, Inc.
Smart Infrastructure
1000 Deerfield Pkwy
Buffalo Grove IL 60089
+1 847-215-1000

© Siemens Industry, Inc., 2019

Technical specifications and availability subject to change without notice.